

## FLOATING FAB LAB AMAZON | WORKSHOP FAB LAB ARGENTINA

DIRECCION: Asociation FAB LAB Peru [www.fab.pe](http://www.fab.pe)

TUTOR PERU': Beno Juarez

TUTOR ARGENTINA: Ilaria La Manna

PARTICIPANTS:

Mariano Fressoli

Diego Sebastian Ortigoza

German Vazquez

Erika Hassan

Felipe Arenas

Julia Quiroga

Pablo Lioni

Sabrina Tamashiro

Jimena Califa

Fernando Viviani

Mariano Pedernera

Emmanuel Aguilar

José Erostequi

Lima, 9 Noviembre 2015



**FAB LAB  
ARGENTINA**



**FABLAB** fab.pe  
SUPERNODO LIMA



**FABLAT** FABLABS



Sociedad  
Central de  
Arquitectos

**trotec**  
laser. marking cutting engraving







The Floating Lab Workshop organized by Fab Lab Argentina every Tuesday from October to December of 2014, included designers, architects, communication and media specialist and sociologist.

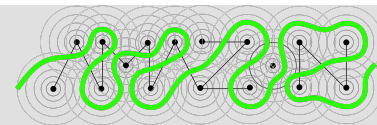



# CONCEPT

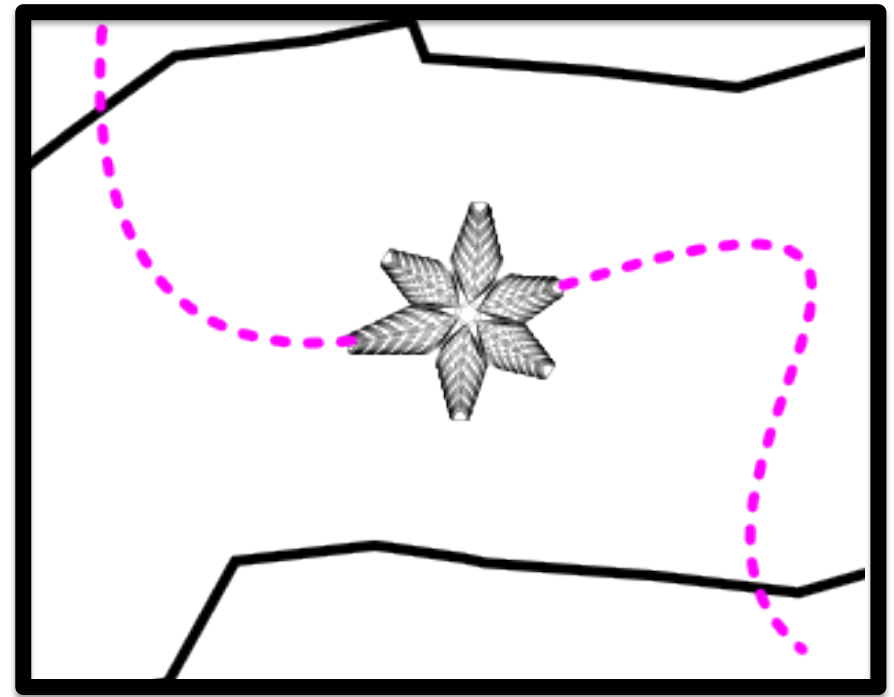
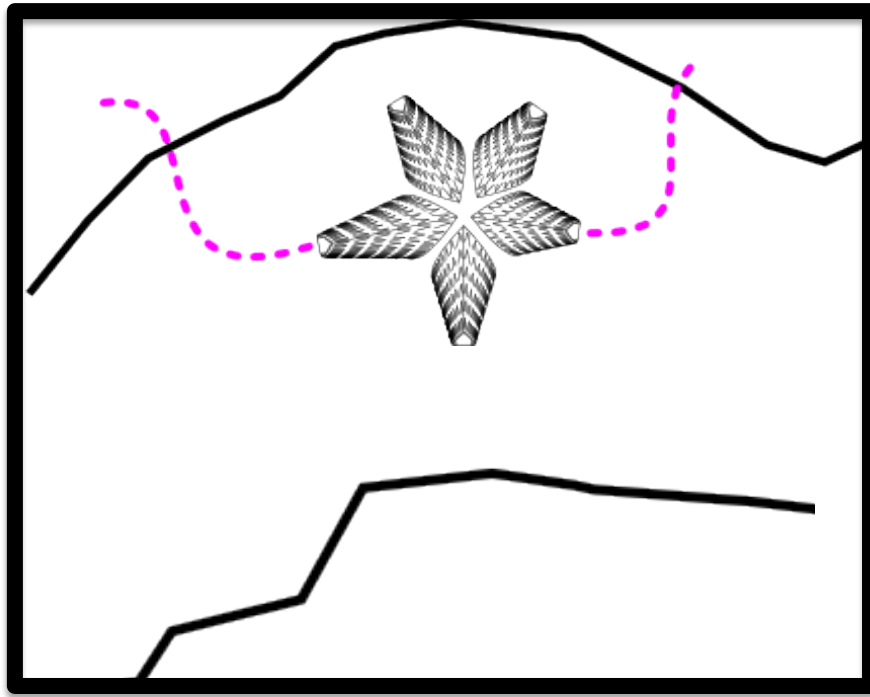

During the workshop we explored the flotation and material properties of several materials and structures.

Different concepts of innovation were outlined, such as:

a) floating and mobile structures, b) mini docking ports, and c) docking joints.

The underlying idea was to design the Floating Lab as a meeting point and a joint space between coast and the river in Belén, which could include research and manufacturing facilities but also space for urban and cultural connection.

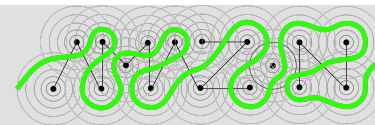



# BELÉN, IQUITOS, PERÚ

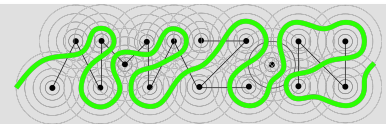
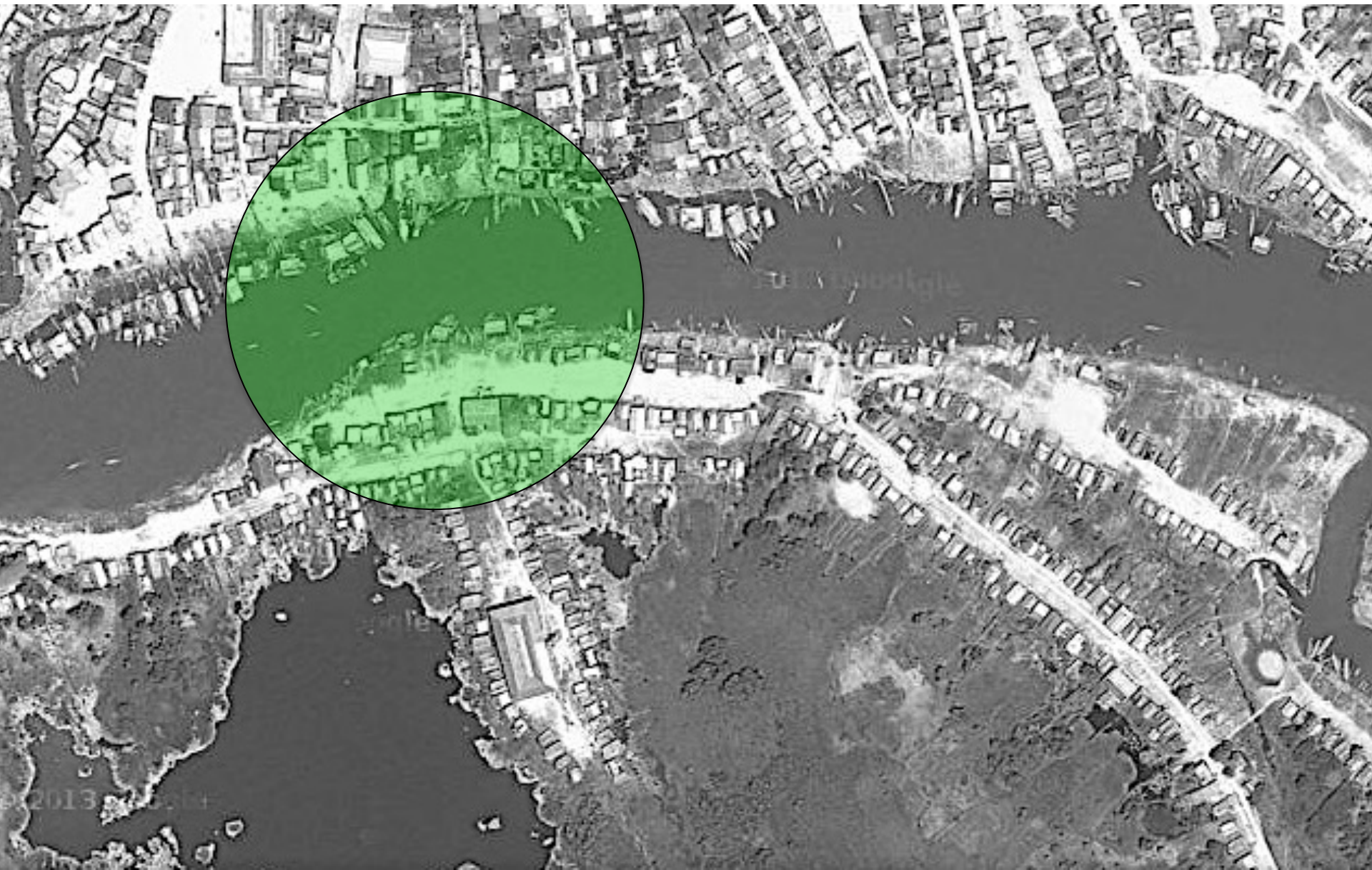



# BELÉN, IQUITOS, PERÚ

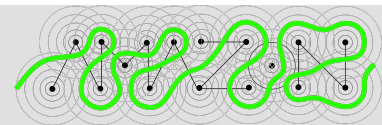



# “MINKA” OPEN COLLABORATION

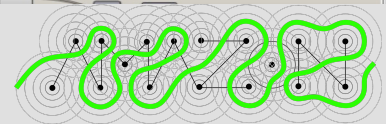
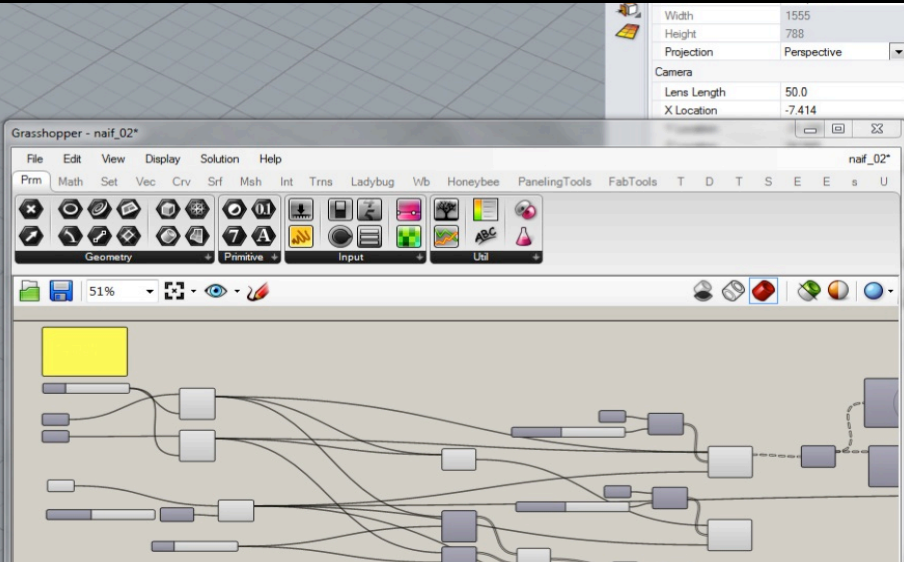
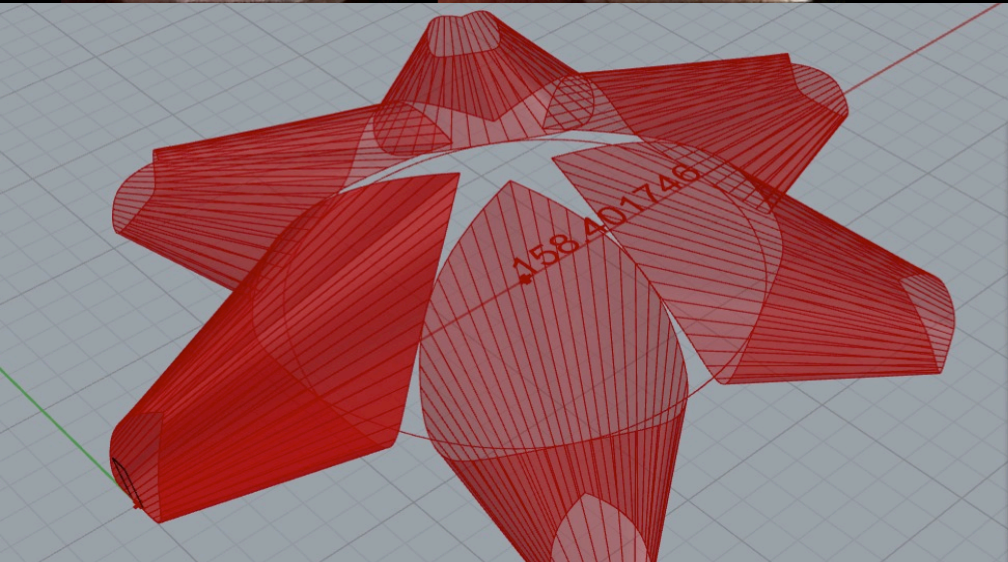
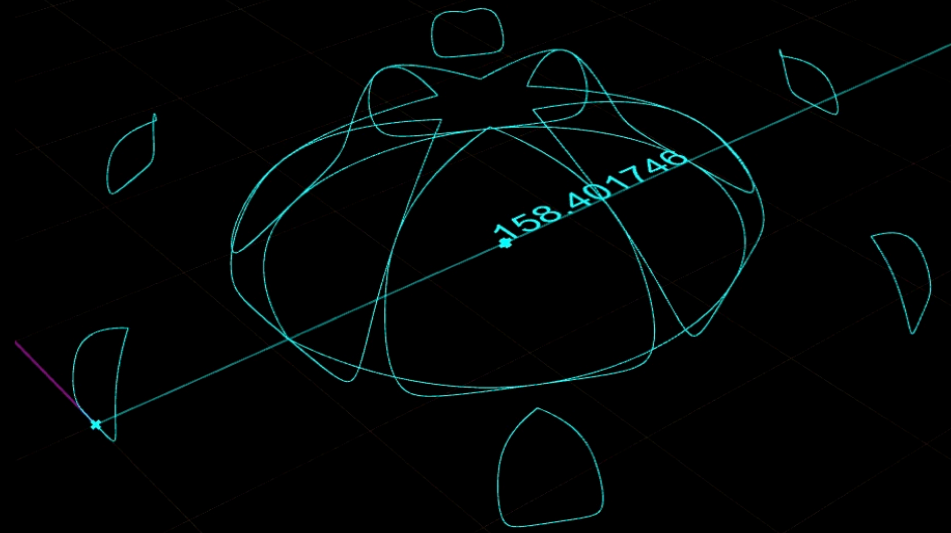

# INITIAL MORPHOLOGY STUDY

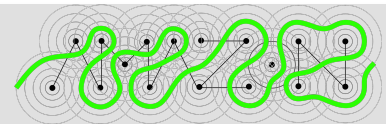
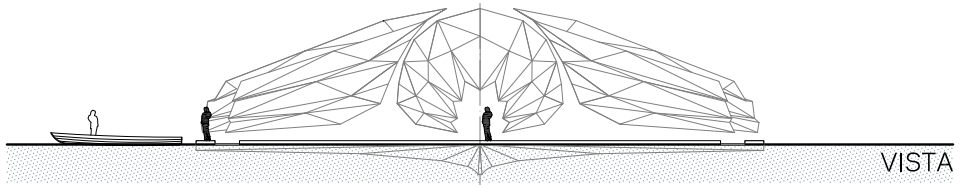
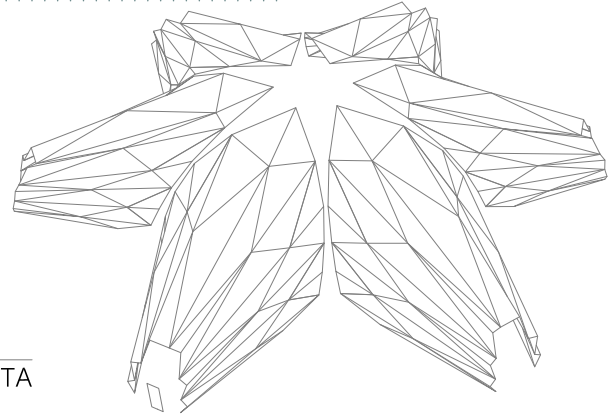
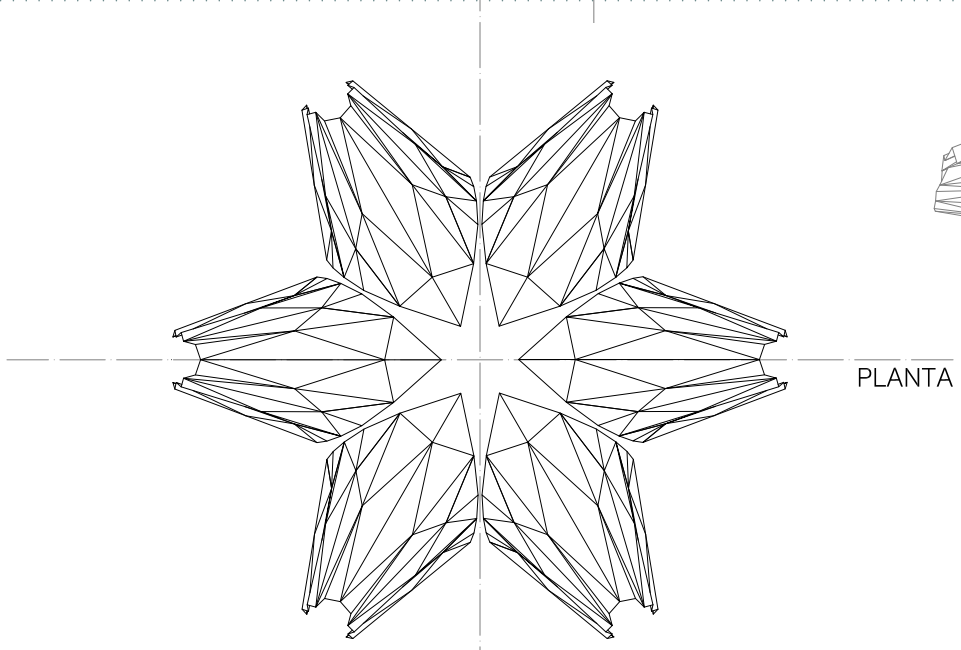
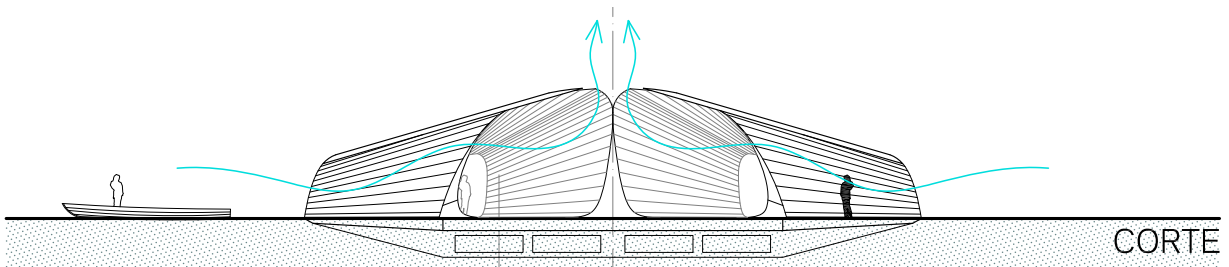



# SPACES AND FUNCTIONS

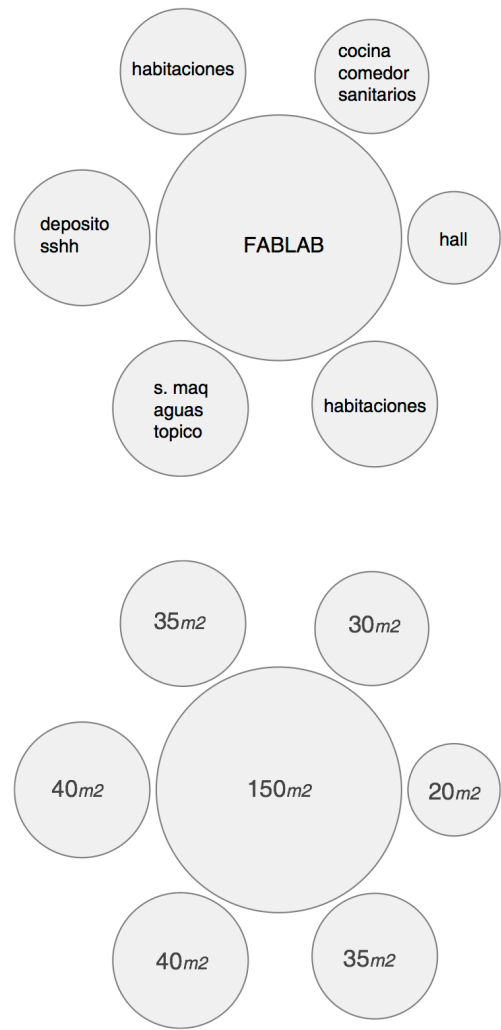

PROGRAM DISTRIBUTION

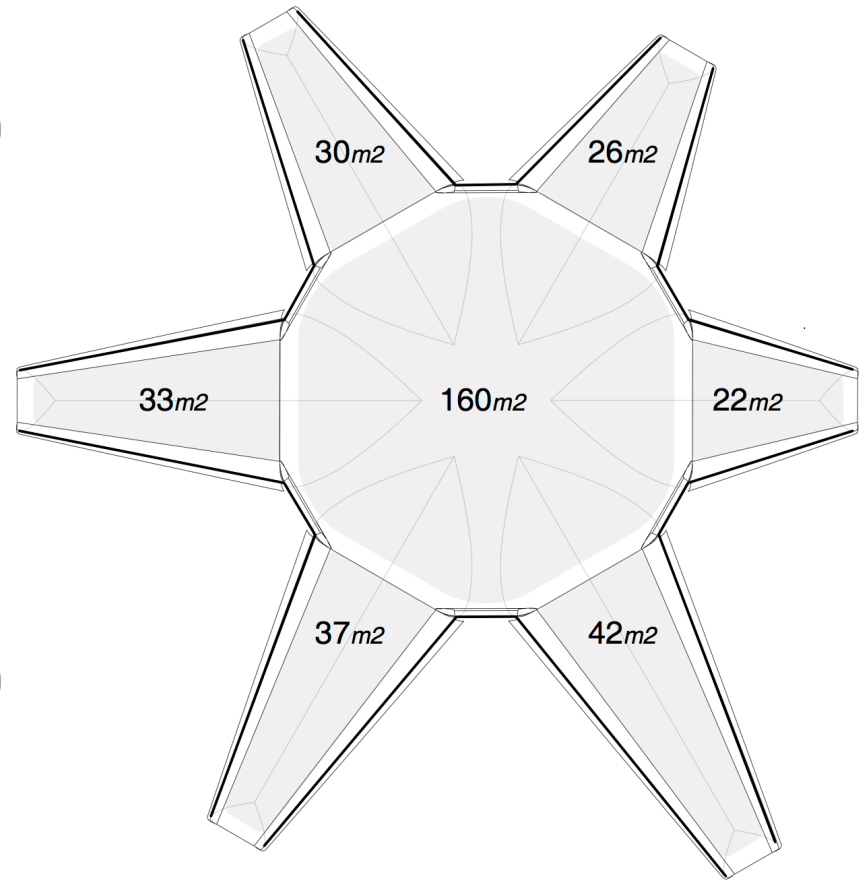

PROTOTYPE TOTAL AREA : 350m2

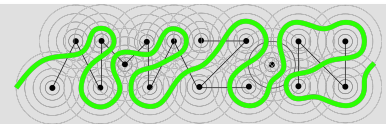
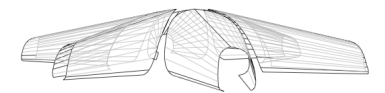
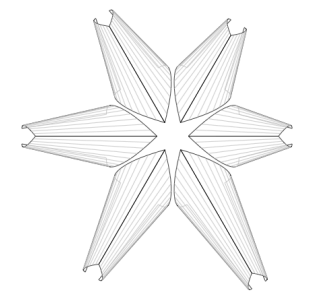
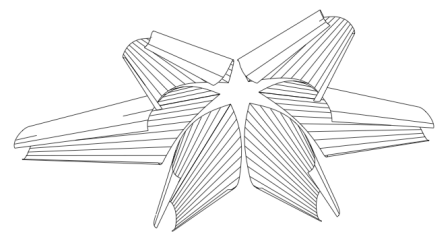

# PROGRAM DISTRIBUTION

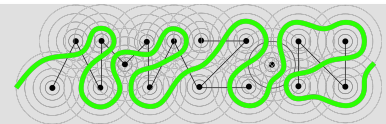
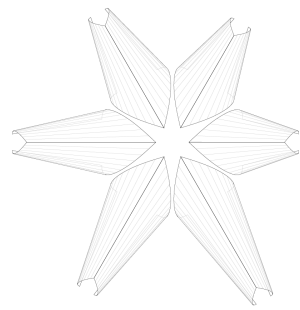
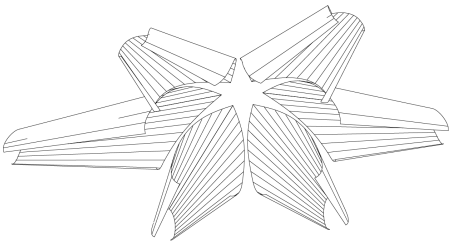
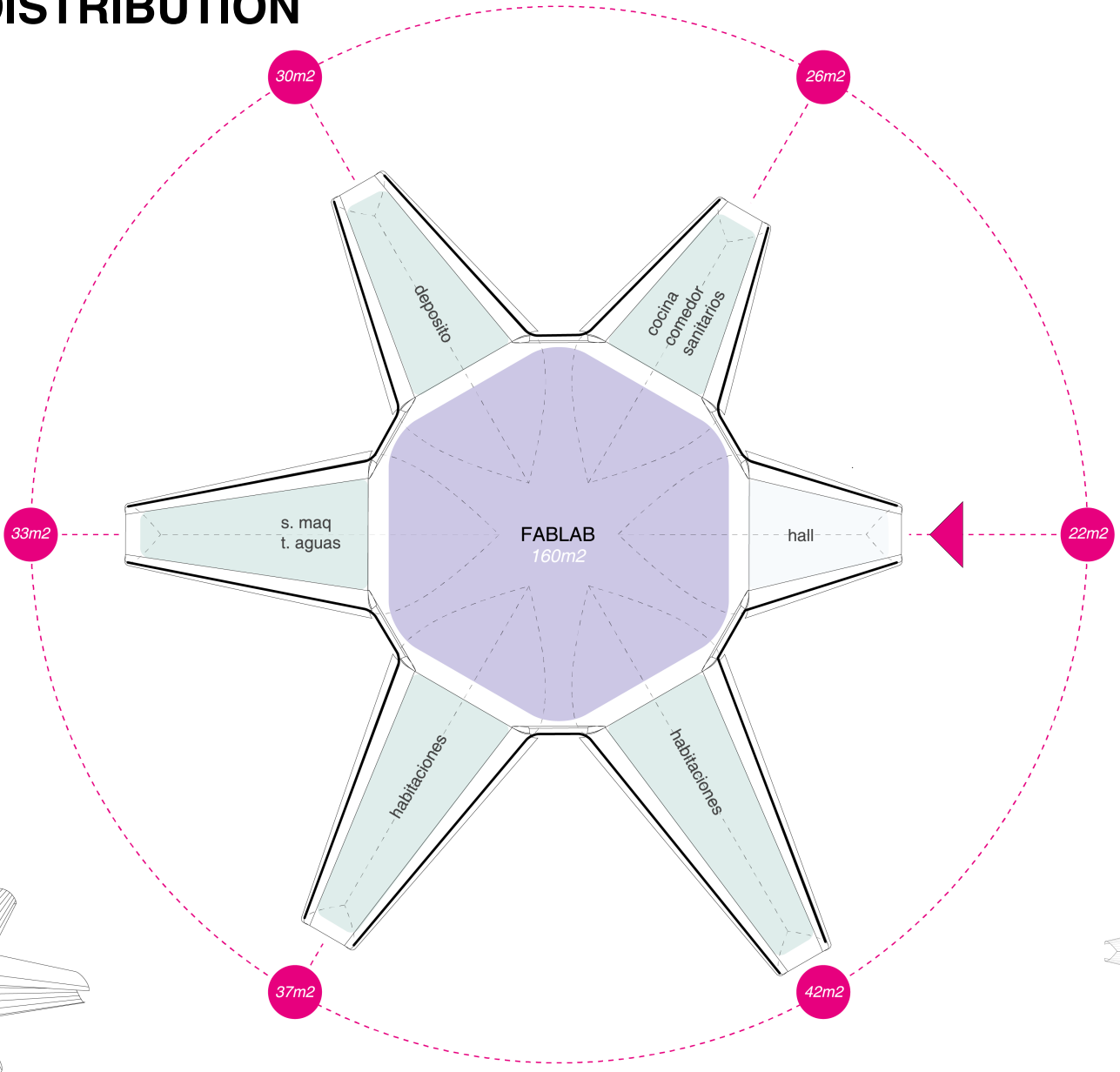



# SYSTEM ELEMENTS

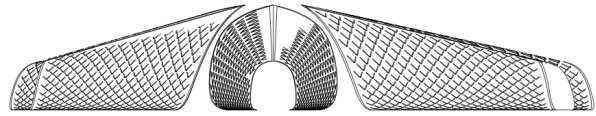
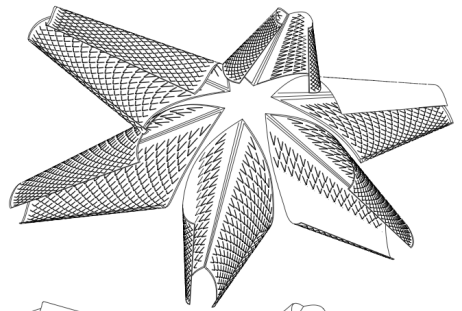

ventilated roof

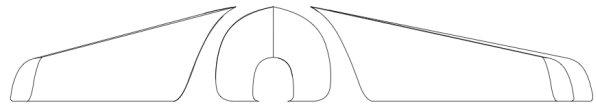
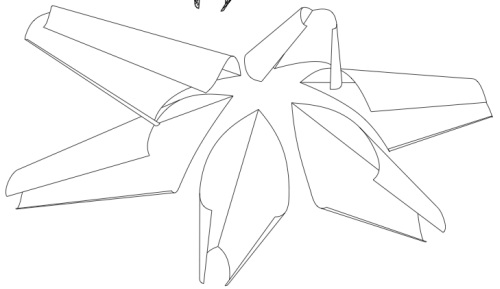
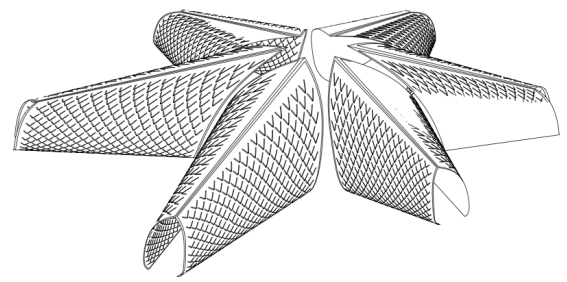

waterproof cover

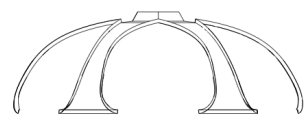
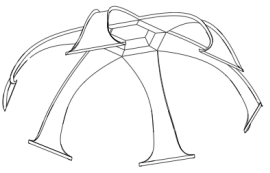
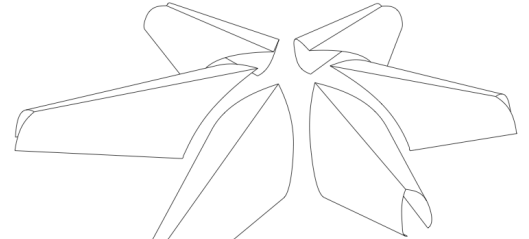

central structure

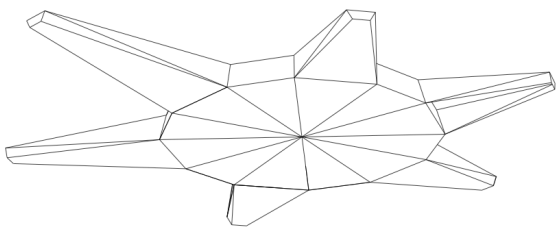
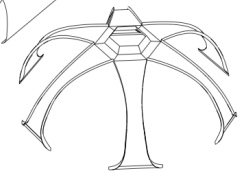

floating platform

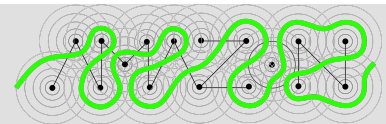
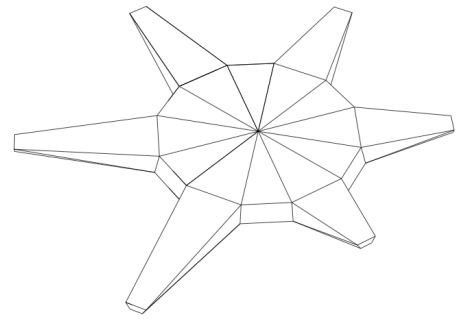

# FLOATING RADIAL PATH TRAJECTORY CONNECTIONS

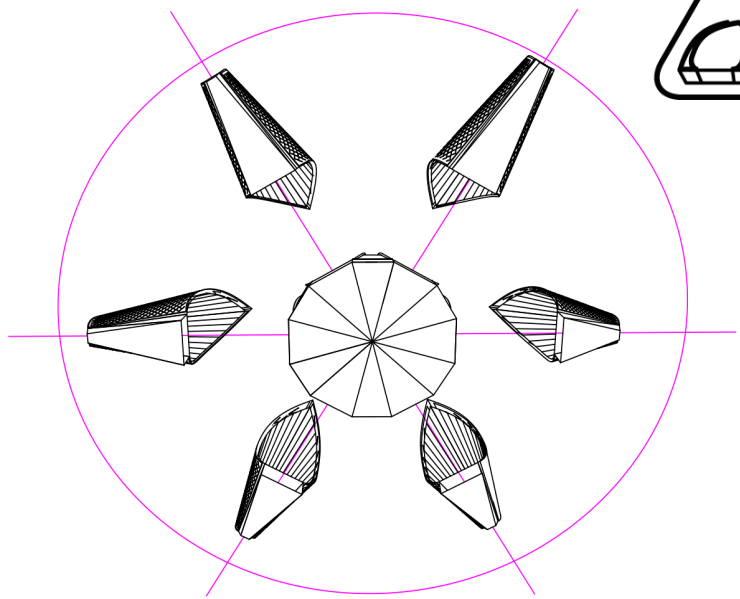
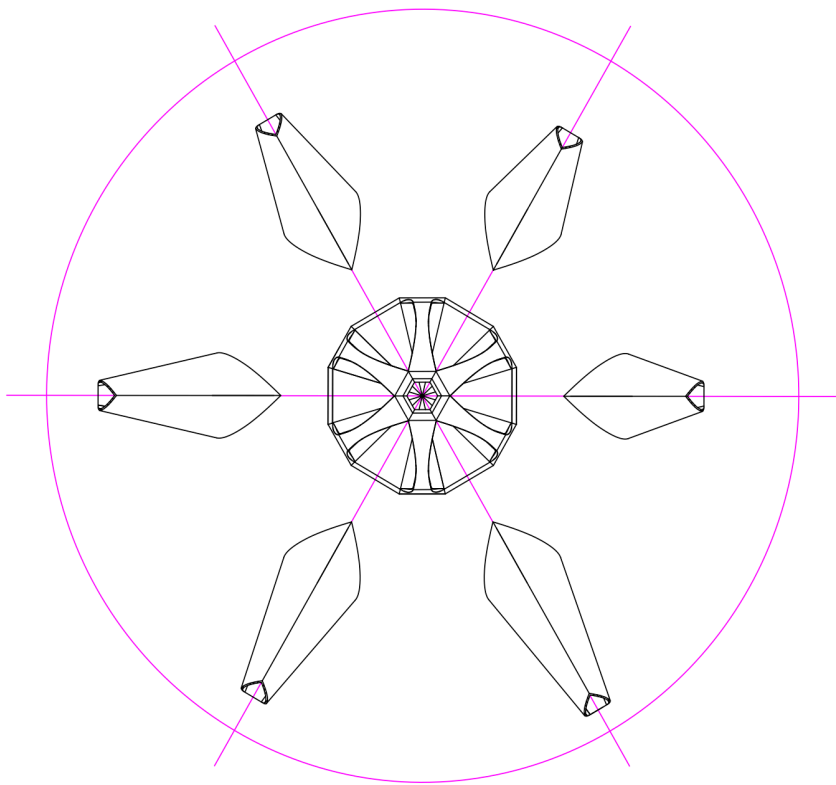

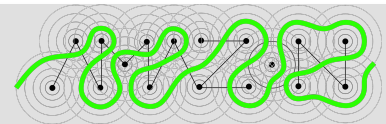

 FLOATING FAB LAB AMAZON



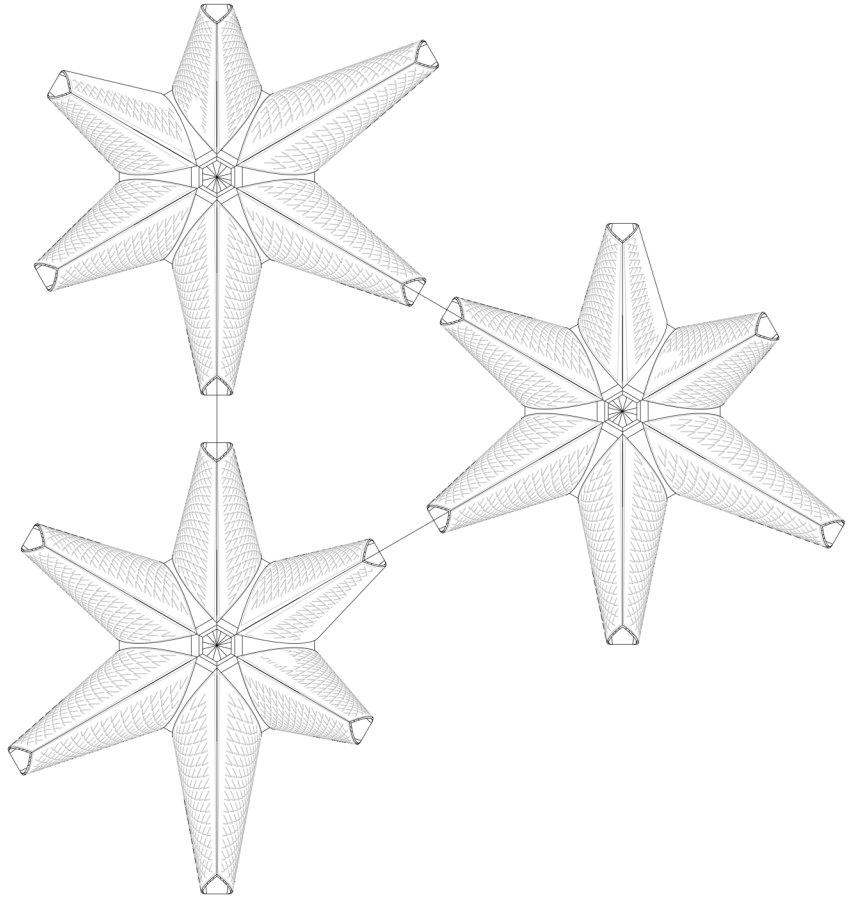
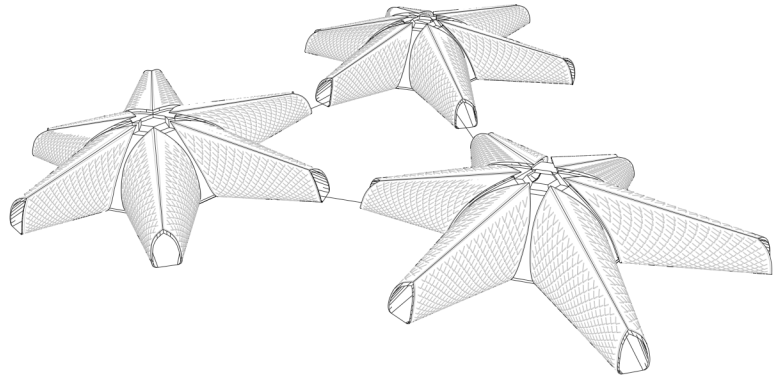
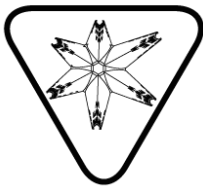

# CELLS MULTIPLICATIONS



 FLOATING FAB COMMUNITY - proliferation

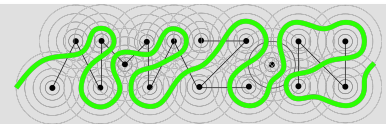

# PERMANENT CELLS

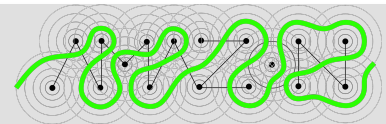
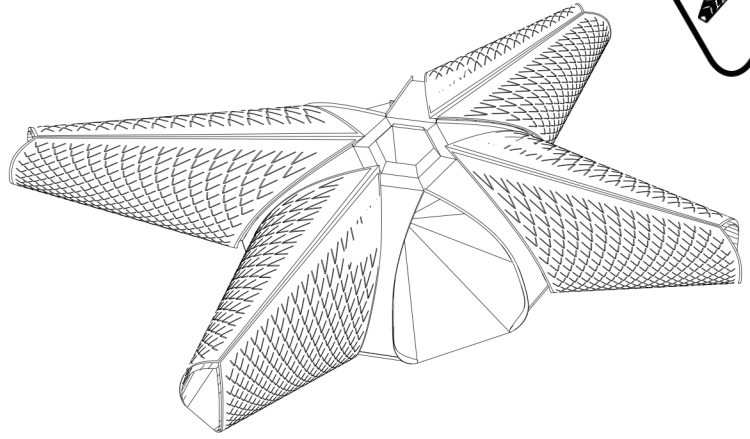
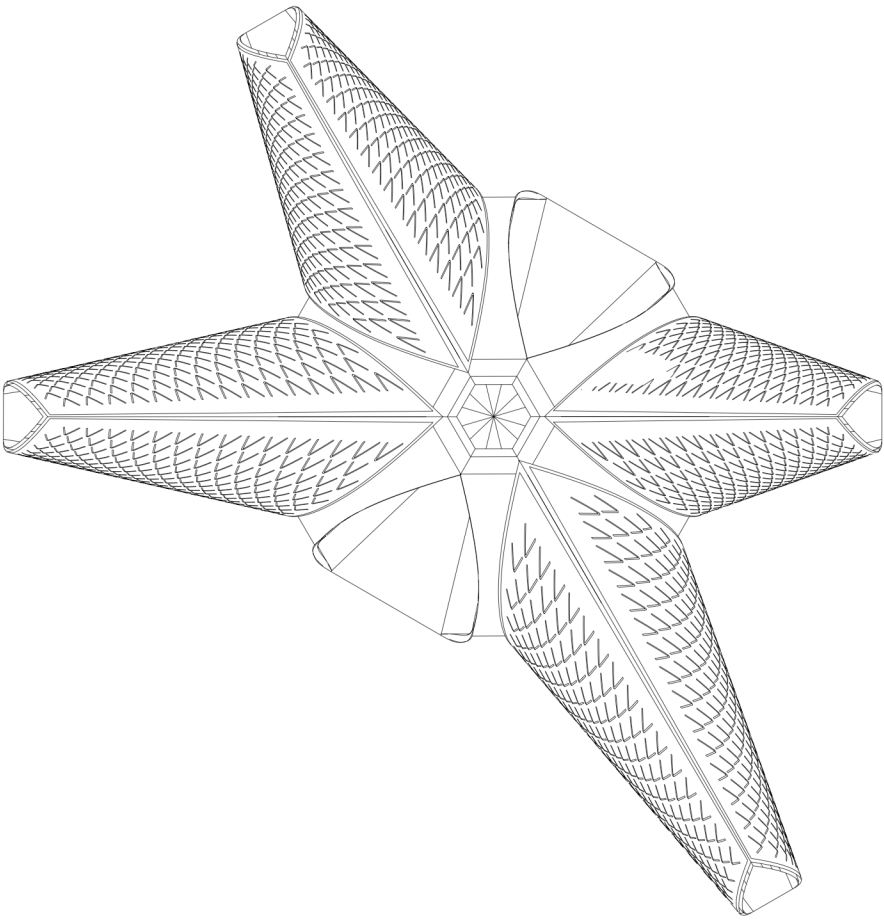



# DOCK CONNECTIONS

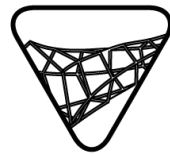

## KIND OF FOOTBRIDGE CONCEPTS ●

Proposal 1. 'Lineal' Type:  
Connect the river bank with the floating FabLab structure.

Proposal 2. 'Surrounding' Type:  
Footbridge that is placed around the structure.

Proposal 3. 'In Union' Type.  
Footbridge that puts together the river bank with  
the structure and, at the same time, connect both  
river coastlines.  
This footbridge allows to get three free petals  
from the structure that can be mobile/movable.

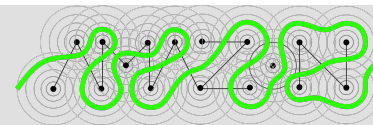

# DOCK CONNECTIONS

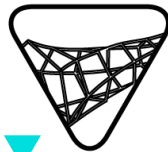

Evolution\_Proposal 'Lineal' Type

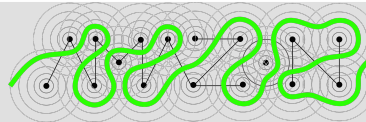
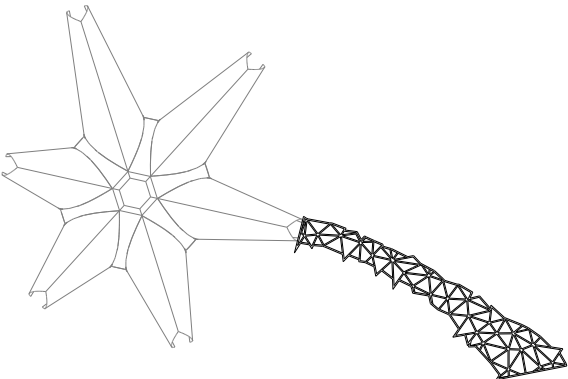
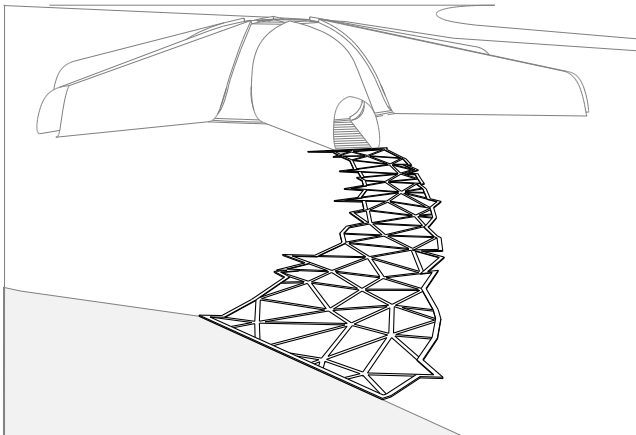
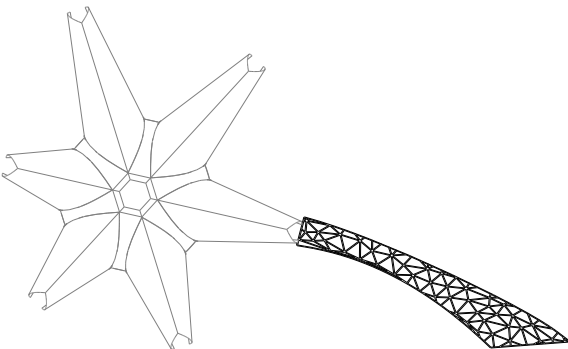
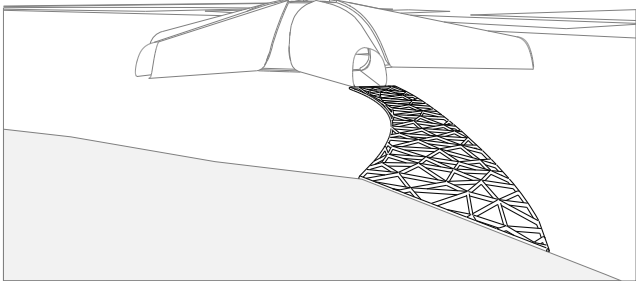
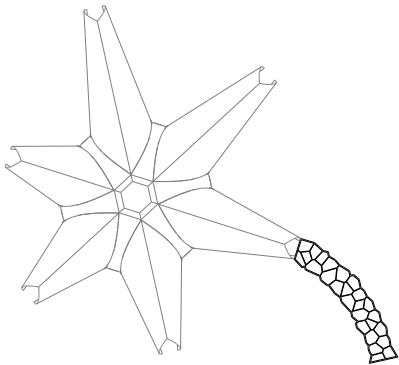
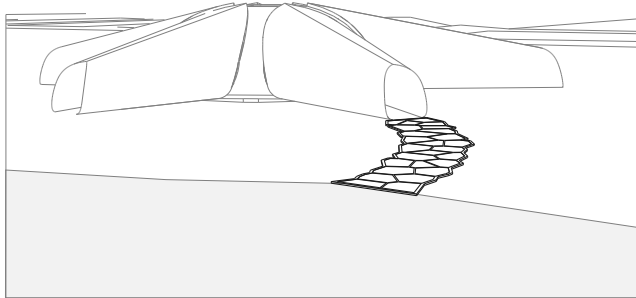



# DOCK STUDY

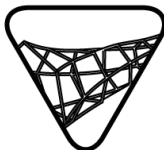

Evolution\_Proposal 'Surrounding' Type ▼

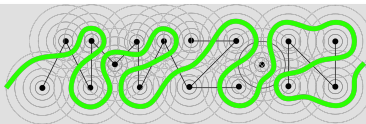
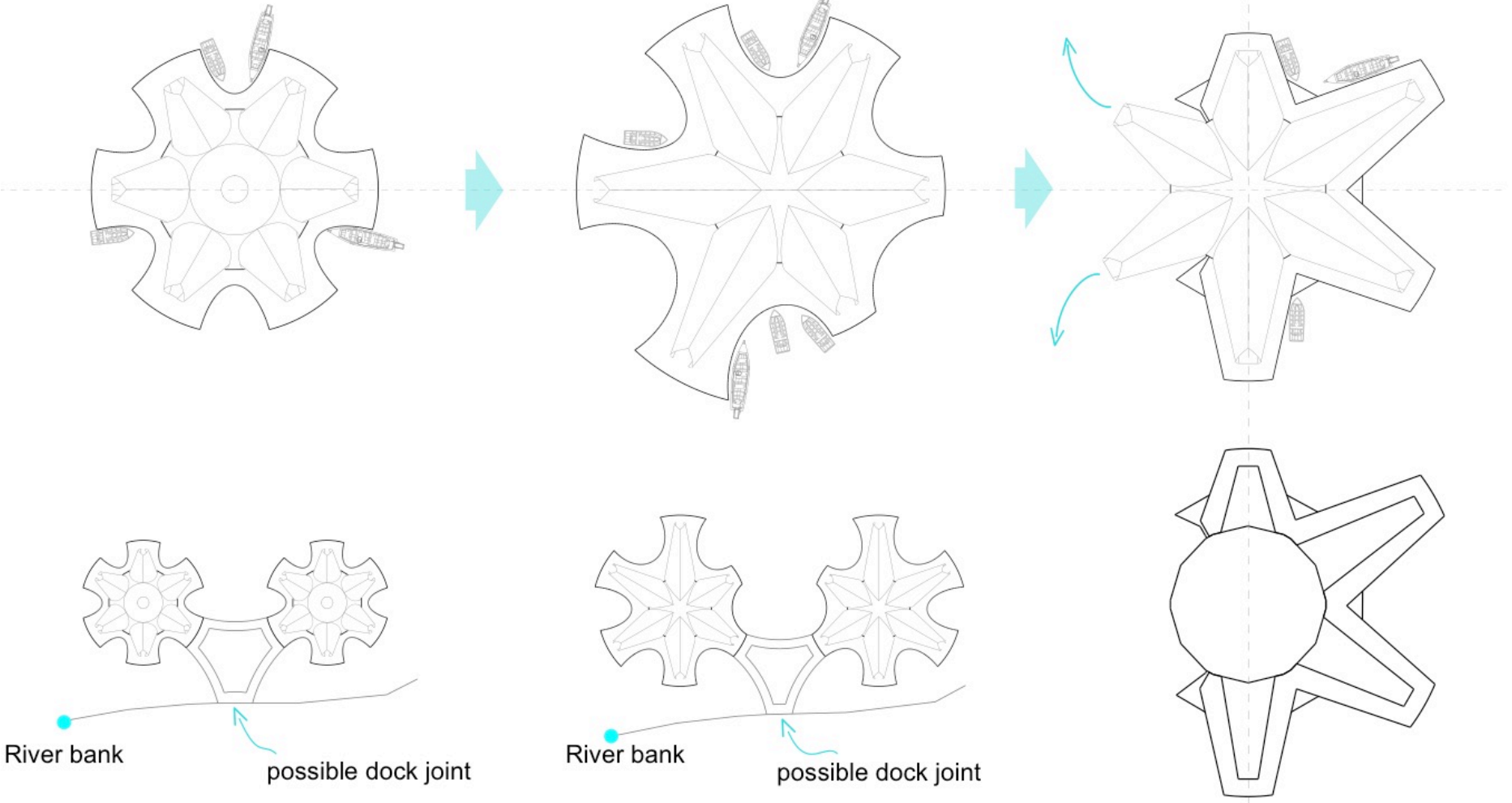

# SKIN LAYERS

Iguana skin



Breathe in skin, balsa wood

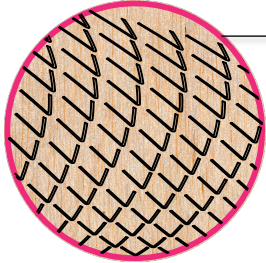

Laser cut fabrication

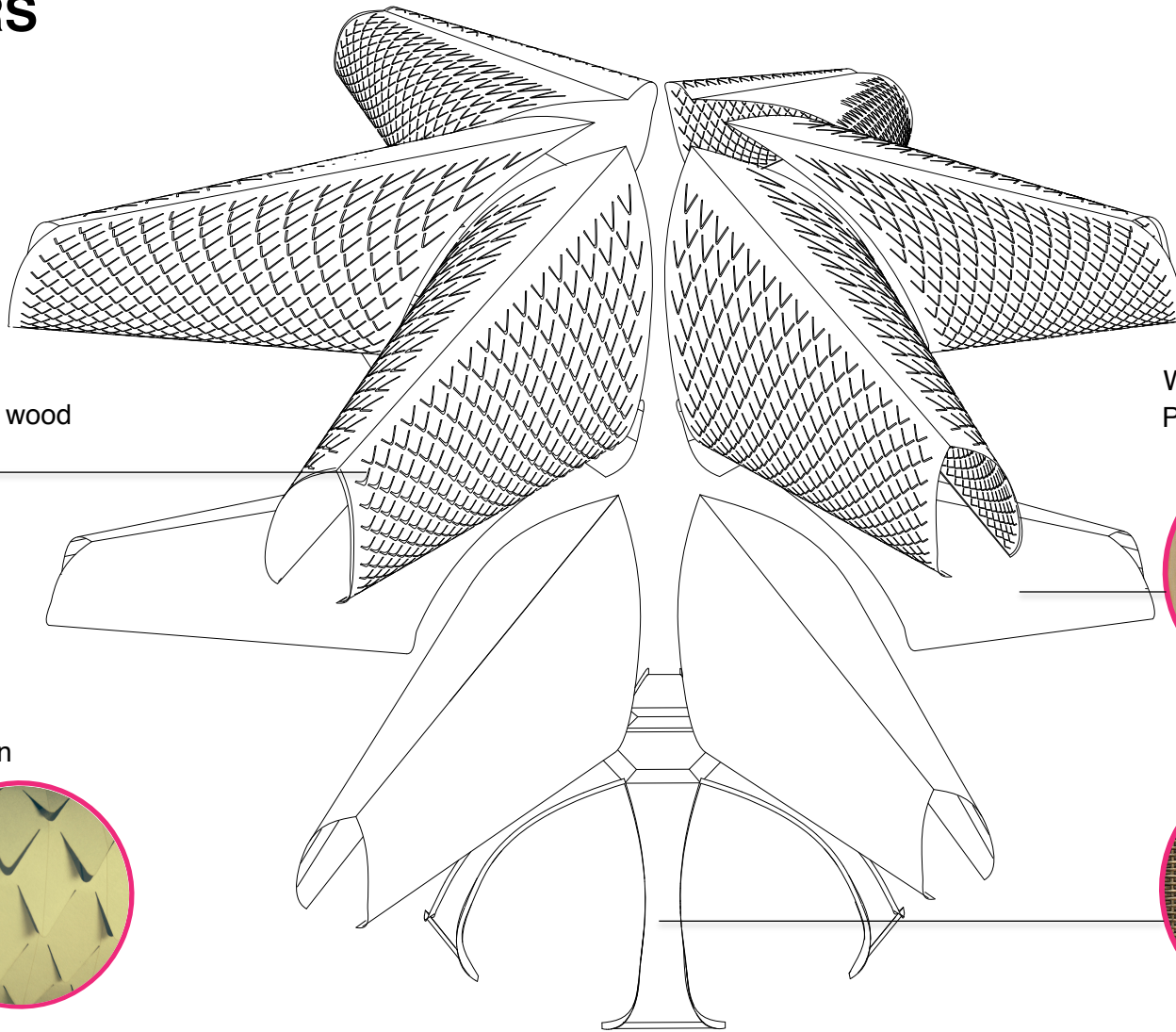
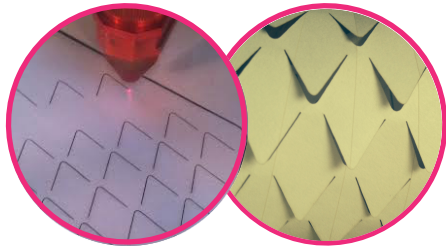

Waterproof membrane  
Plywood sheet



Liana network

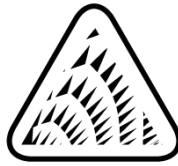
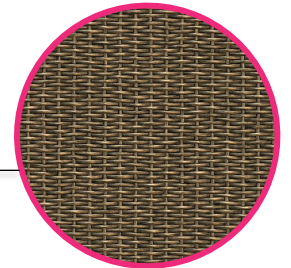

We have think in a double skin: An under skin for protection that will be connected to the structure of each petal.  
Material: Balsa wood. The top skin will be use a flakes or scales (in a similar fashion to a lizard).  
This will allow a better ventilation at the same time that assures water resistance. Theses scales will be made using a router.

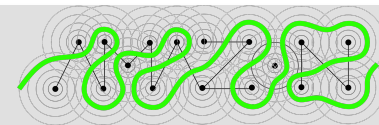

# FLOATING CELLS VENTILATION CYCLE

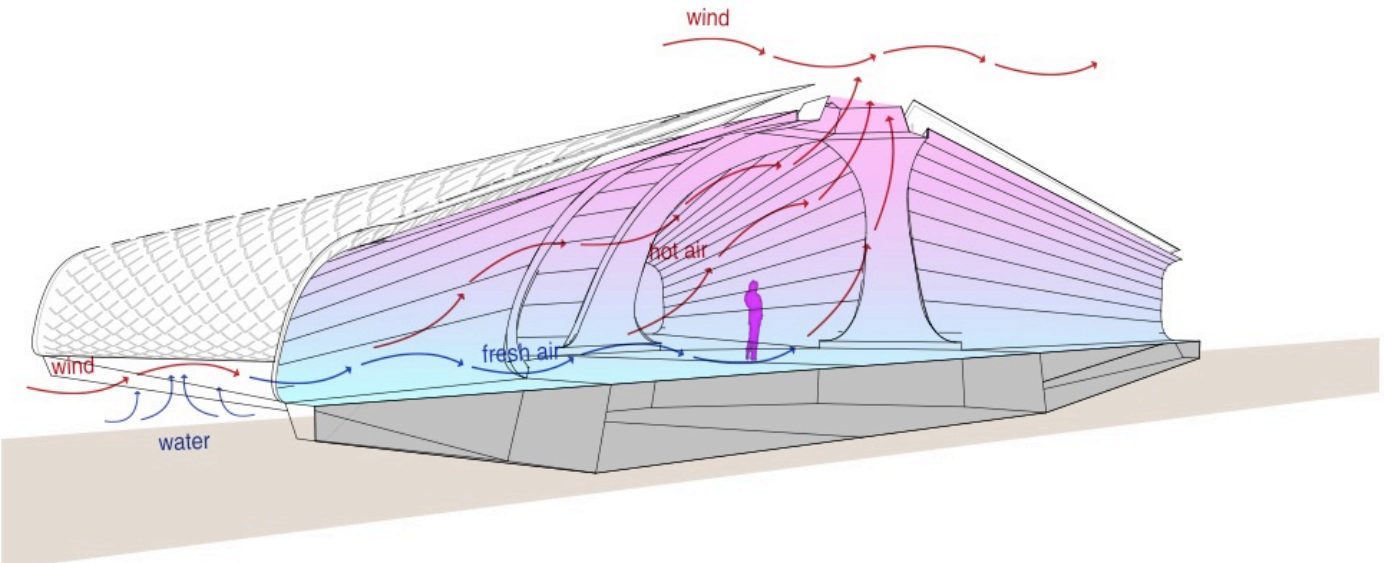

SECTION

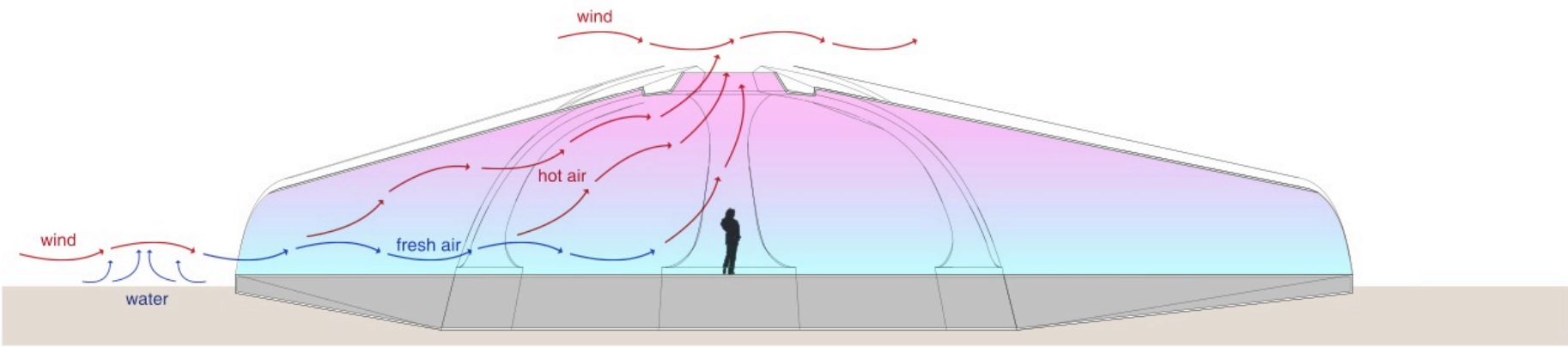

solar chimney

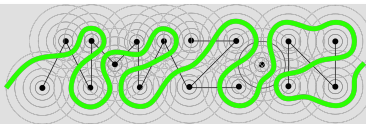



# FLOATING CELLS DIMENSIONS

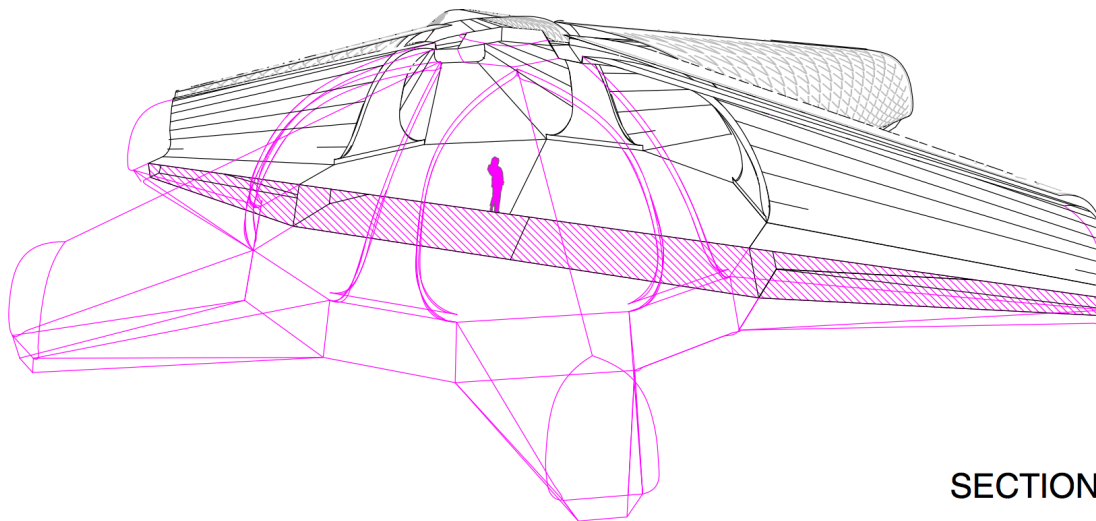
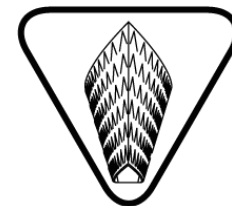

SECTION

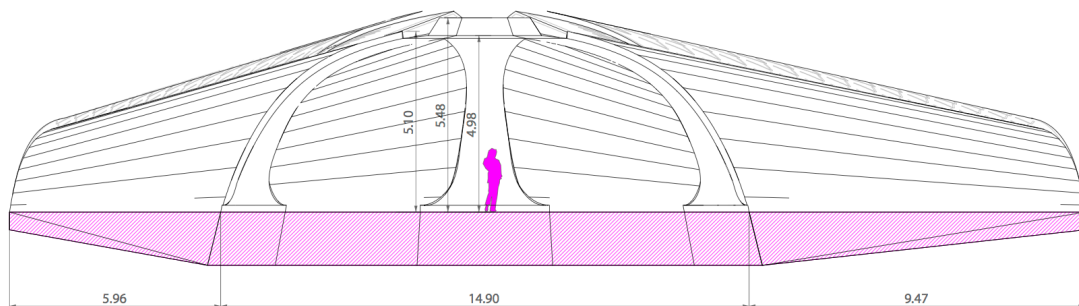

section - dimensions

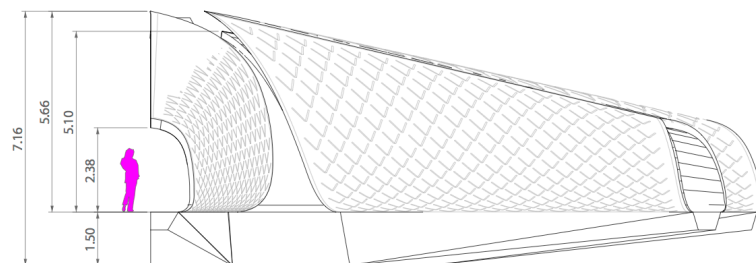

section - dimensions

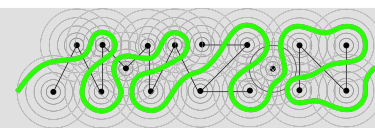

# FLOATING CELLS STRUCTURE STUDY

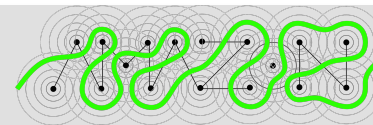
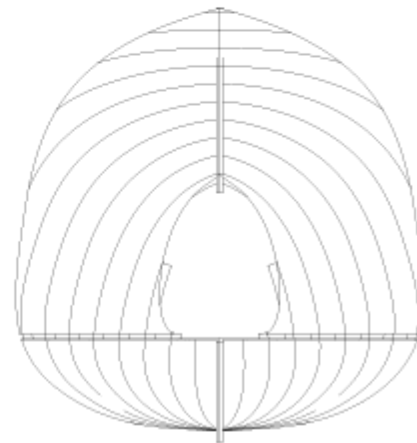
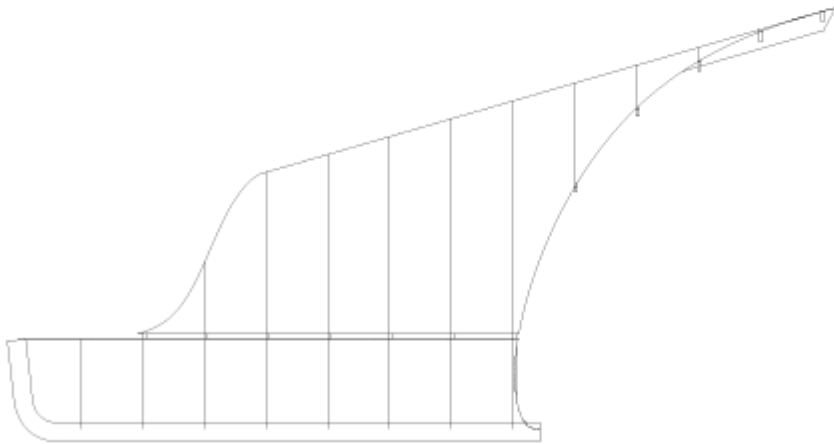
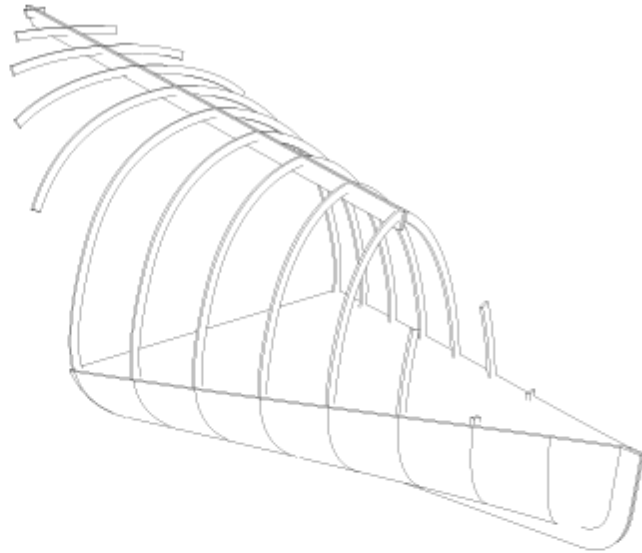
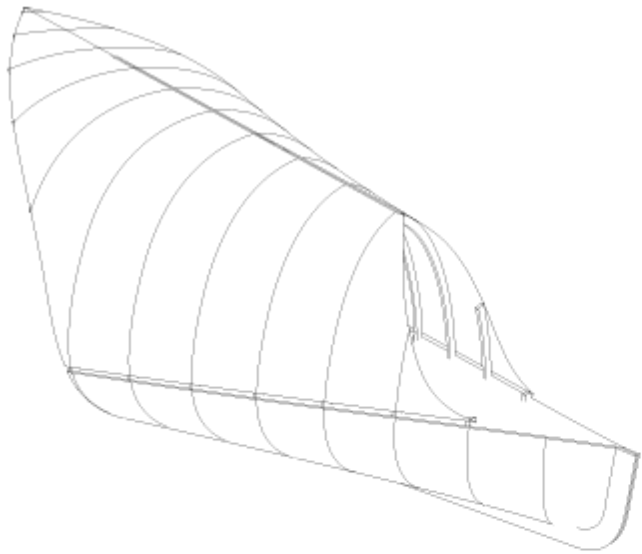

# CELLS STRUCTURE OPTION 1

bamboo  
stereostructure

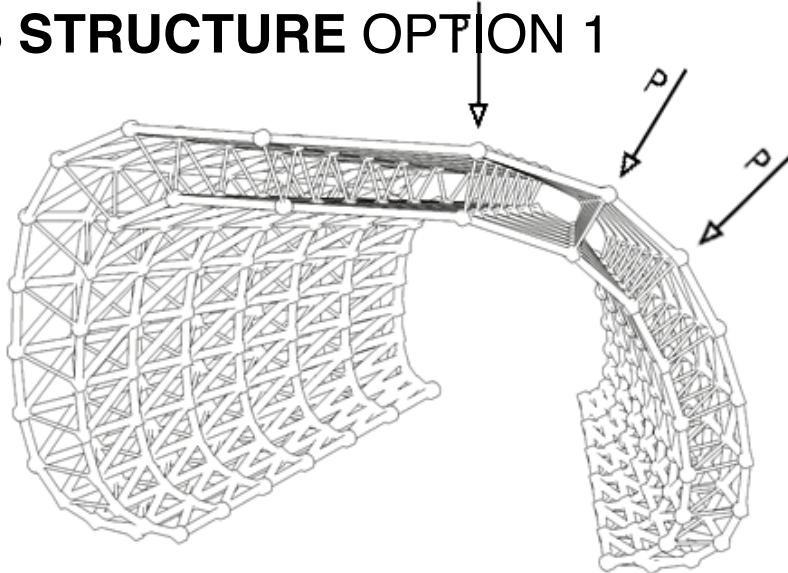

Two overlapping structures that work and exploit internal properties from bamboo pipes. As roof truss, composed by nodes and bars.

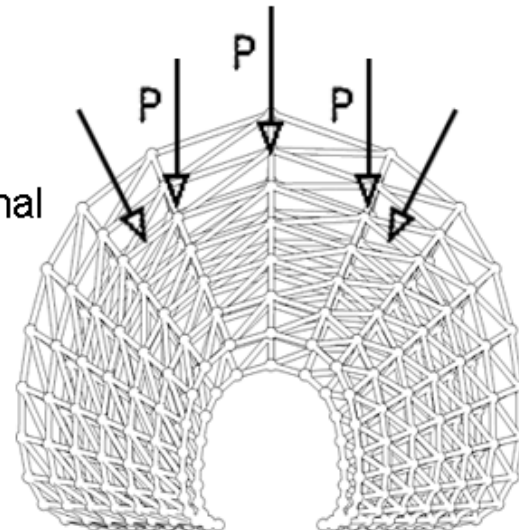

joints:

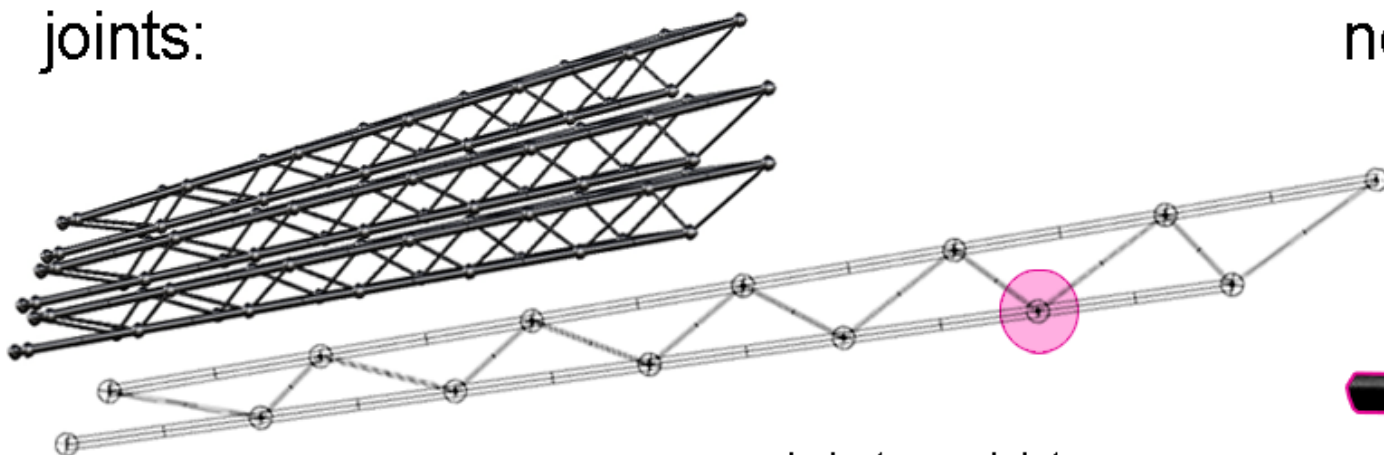

nodes:

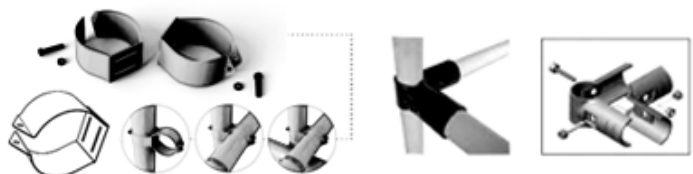
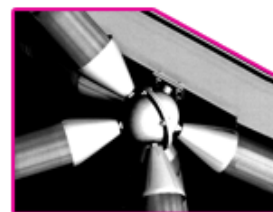

in-between joint, the element adapts to the bamboo pipe. Allows the longitudinal continuity and the superposition on different planes.

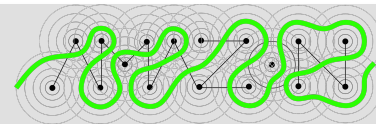
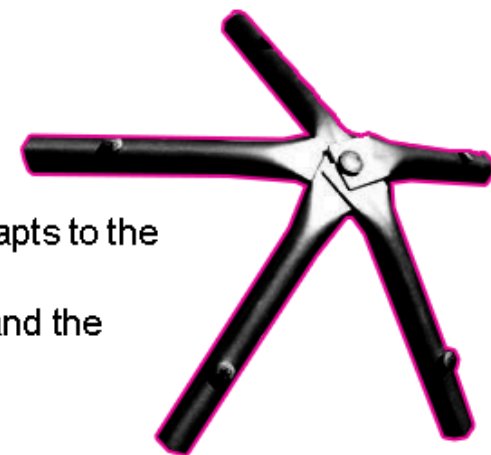



# CELLS BAMBOO STRUCTURE OPTION 2

bamboo  
structure  
struts

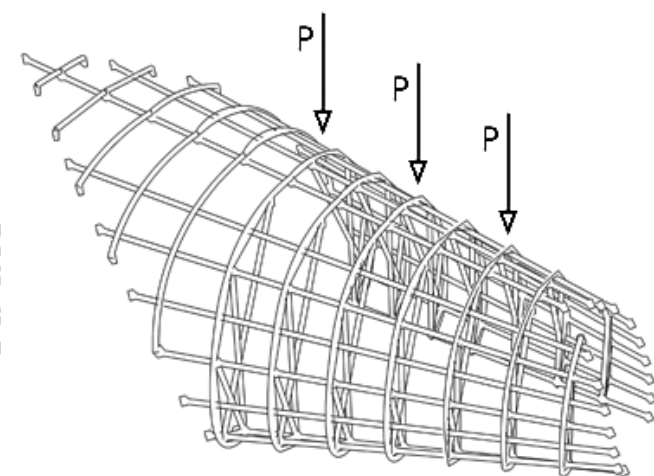

**strut:**  
structure that works  
independently,  
allowing dimensional  
variations  
and future  
constructive  
adaptability

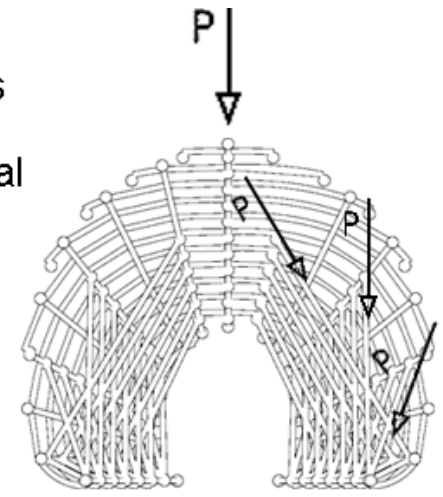

joints:

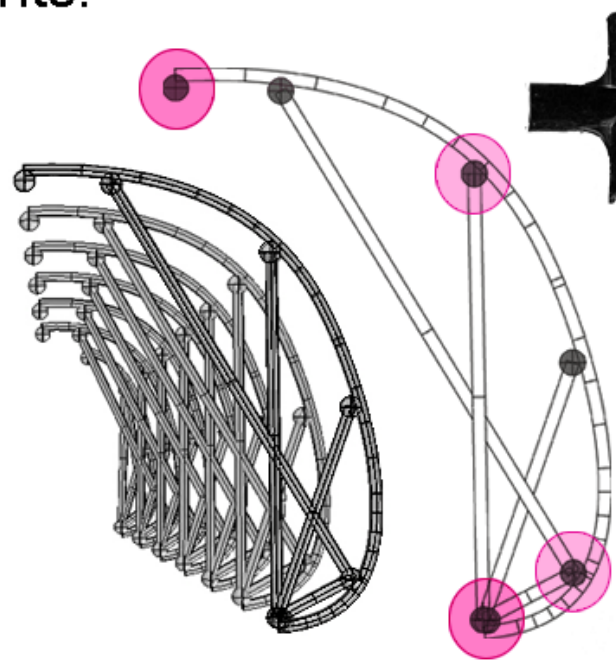

**cross joint, the bamboo pipe adapts to the element.**  
Allows to deviate in different orthogonal angles.

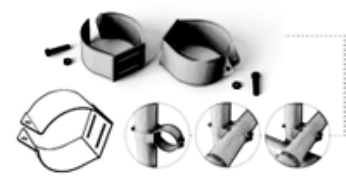

**in-between joint, the element adapts to the bamboo pipe.**  
Allows the longitudinal continuity and the superposition on different planes.

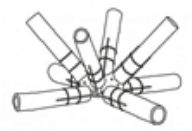

**base joint, the bamboo pipe adapts to the element.**  
Allows the confluence of many struts and an optimal connection to the basement.

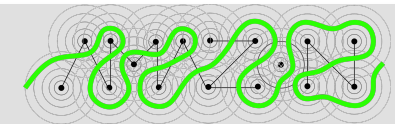

# UPPER CORE OPTION 1. STRUCTURAL BAMBOO

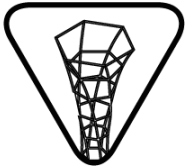

>structural module  
in bamboo

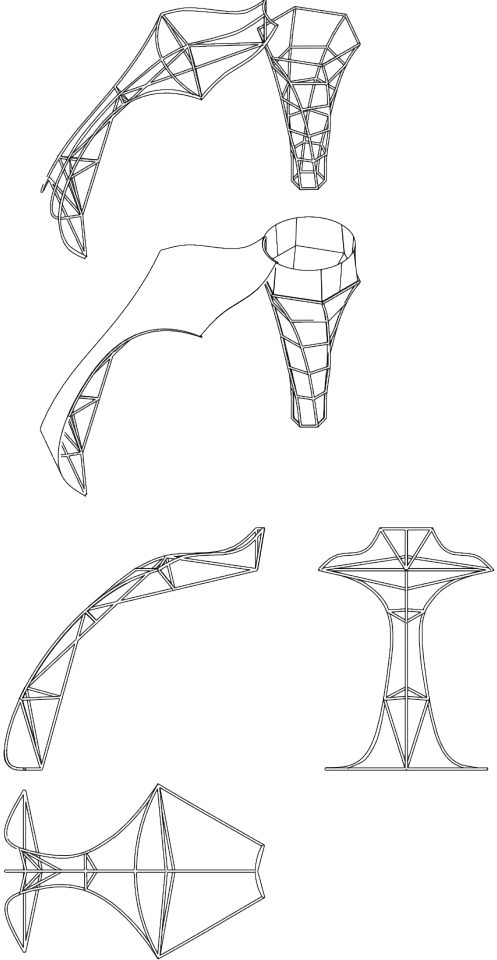

>2 components:  
tissued skin+frame

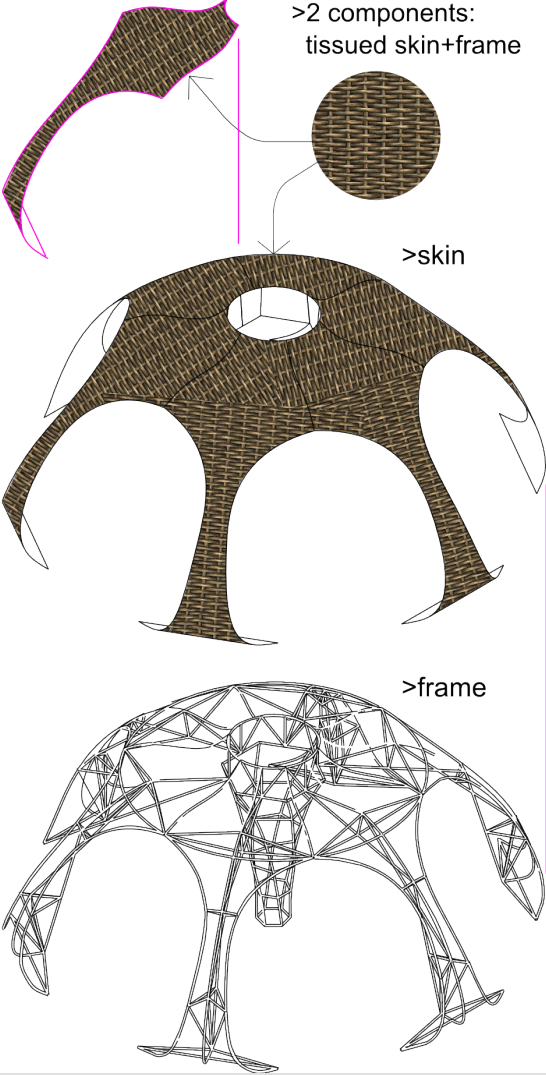

>Core, top view

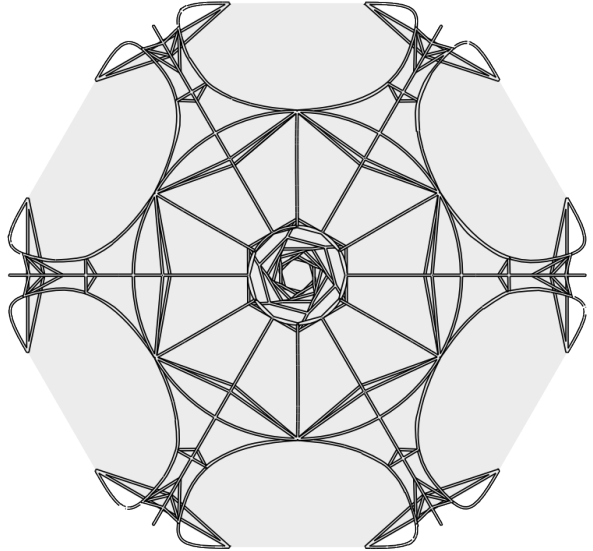

>Core, side view

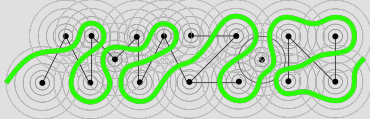
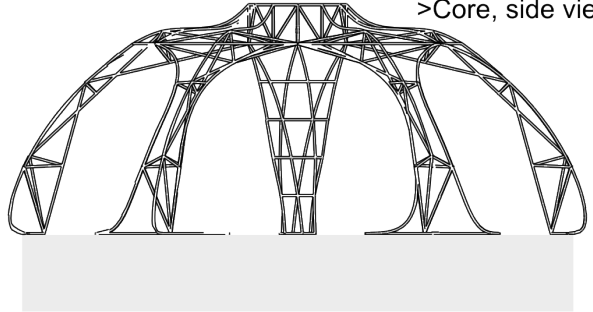

# UPPER CORE OPTION 2. MONOCOQUE

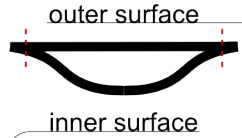
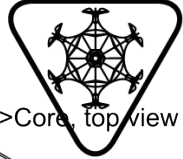

"Is a structural approach that supports loads through an object's external skin, similar to an egg shell. The term is also used to indicate a structure in which the skin provides the main structural support."

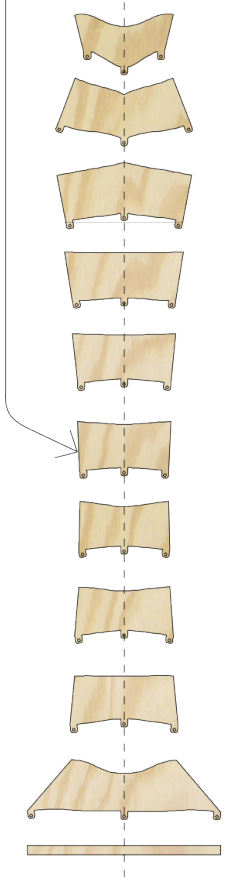

>development

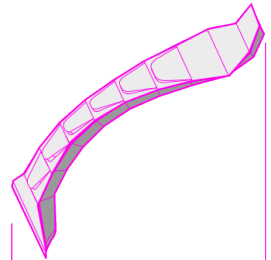
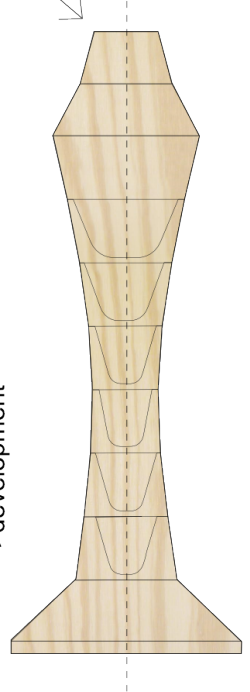

>structural module in plywood

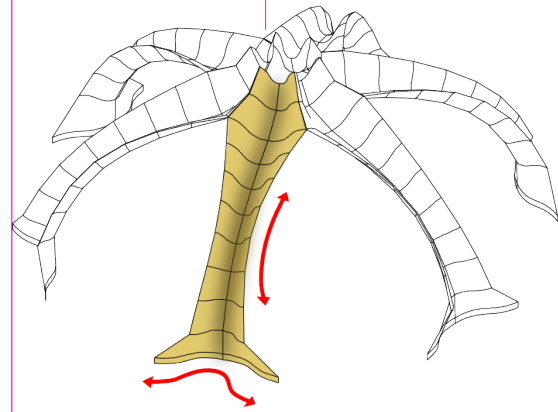

>inner surface, double curved

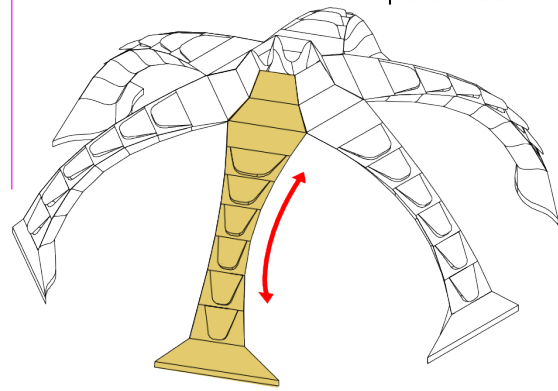

>outer surface, simple curved

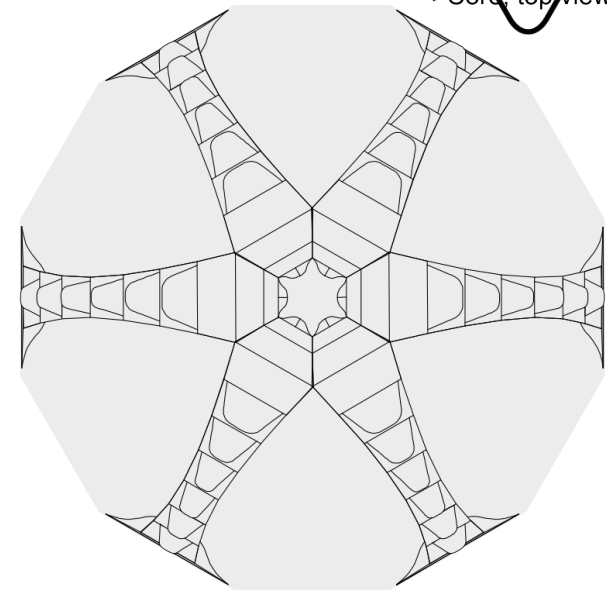

>Core, top view

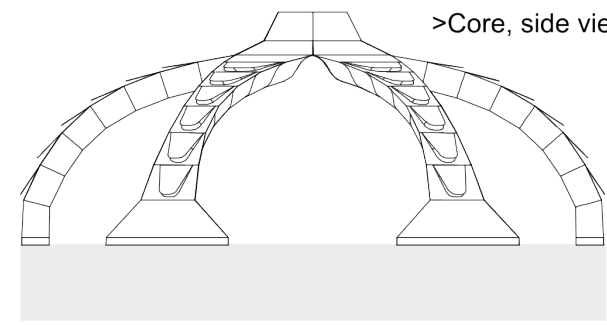

>Core, side view

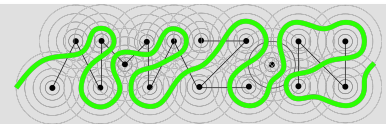



# BASE STRUCTURE MECHANICAL DETAILS

River flow and floating body action/reaction system

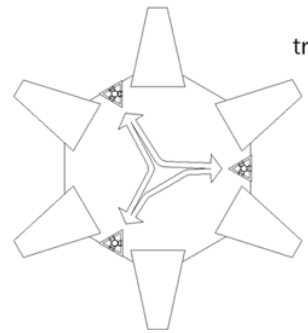
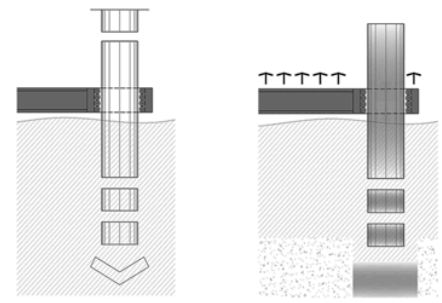
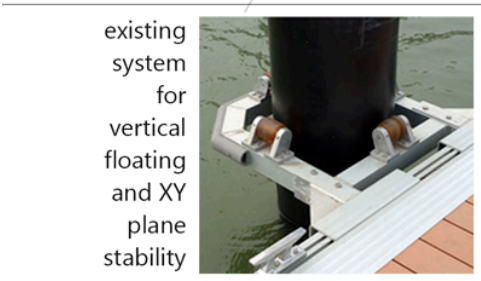
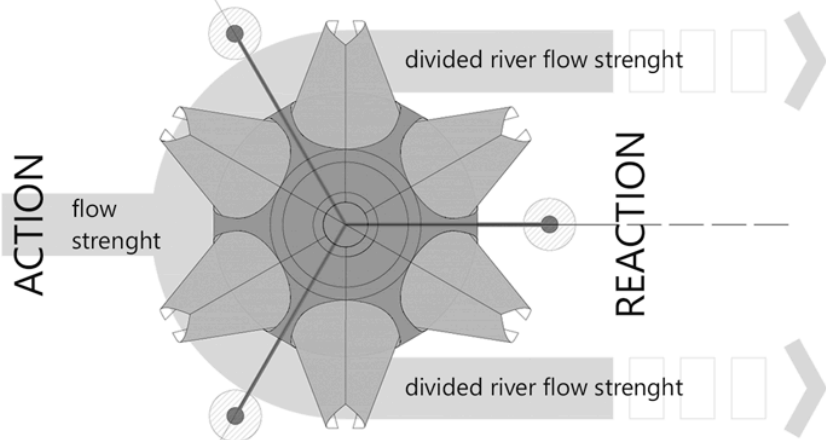

triangular shape responds best for stability and strenght when applied under wide loads and pressure.

disposing structural elements on a triangular order on a surface, will act properly upon incoming forces and distribute them best.

Roller contour structure plans  
plan view

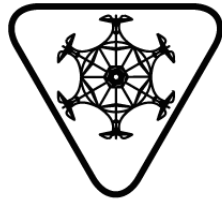

Since the triangle shape was chosen due to its non-deformable strenght, it should also be taken in the design of the roller contour structure.

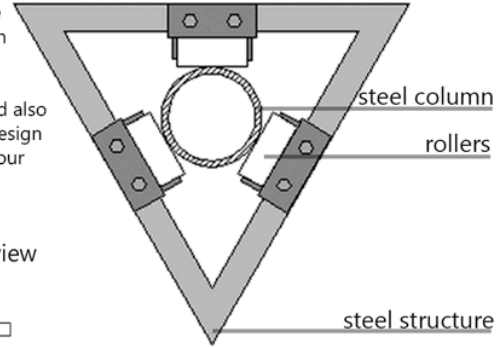

elevation view

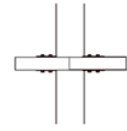

section view

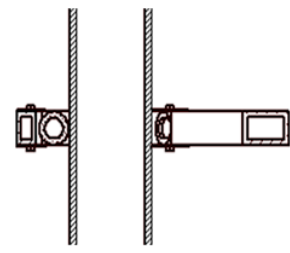

perspective view

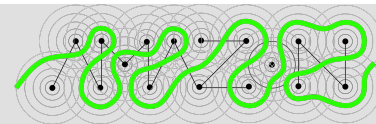
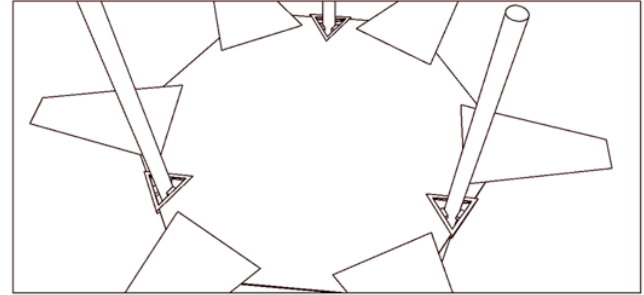
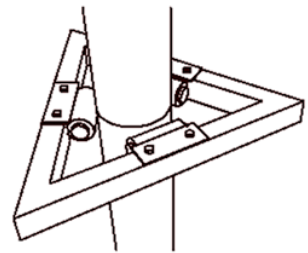

# STABILITY STRUCTURE PROPOSAL

## Proposal A - Vertical steel columns

TOP View

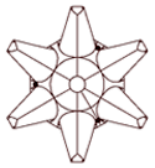

PERSPECTIVE View Complete Body

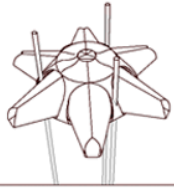

PERSPECTIVE View Partial Body

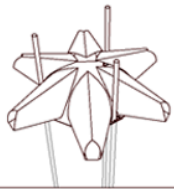

PERSPECTIVE View On Base

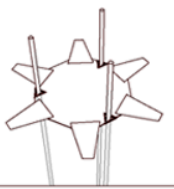

### Movement aligned on vertical 'z' axis

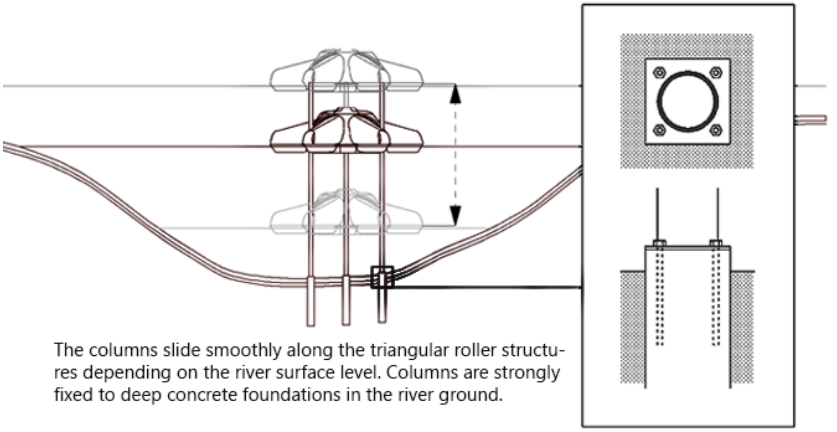

The columns slide smoothly along the triangular roller structures depending on the river surface level. Columns are strongly fixed to deep concrete foundations in the river ground.

## Proposal B - Tripodlike hooked-steel columns

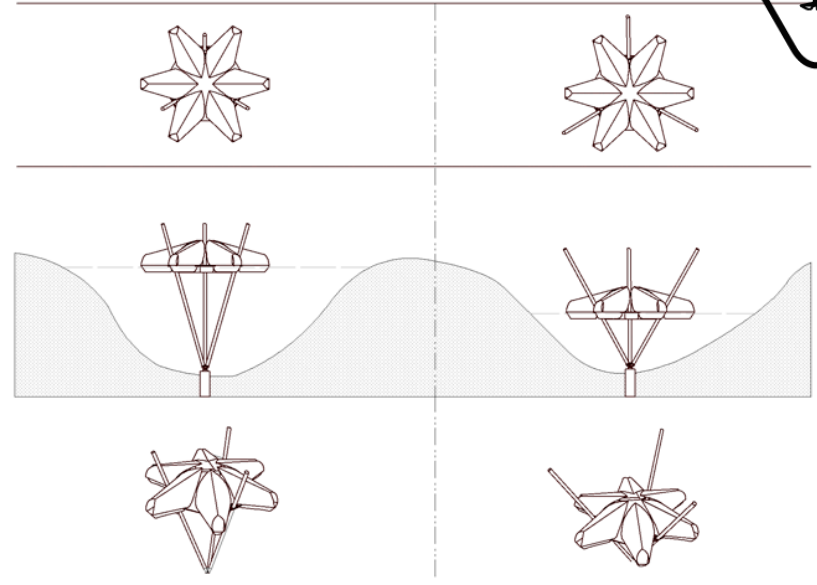
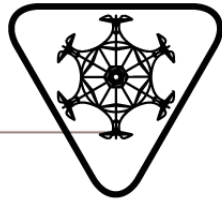

### Node connection system

All three column inferior borders are hooked to a particular ring-like piece fixed to a single concrete foundation.

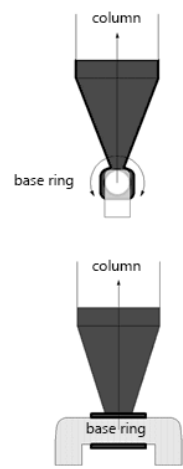
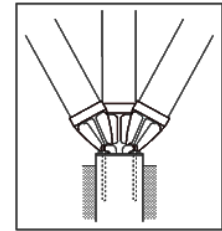

The rings in the bottom allow the columns to rotate in a vertical oblique direction.

In this case, the triangular sliding structure will have a rotation axis so the column stays perpendicular to it and slide with ease.

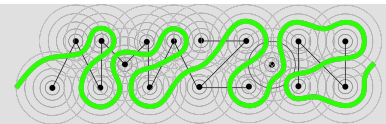
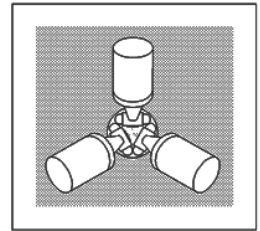

# STABILITY STRUCTURE PROPOSAL

Proposal C - Bi-functional columns & floating path

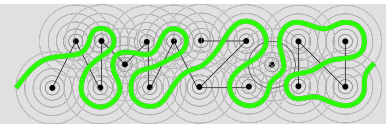
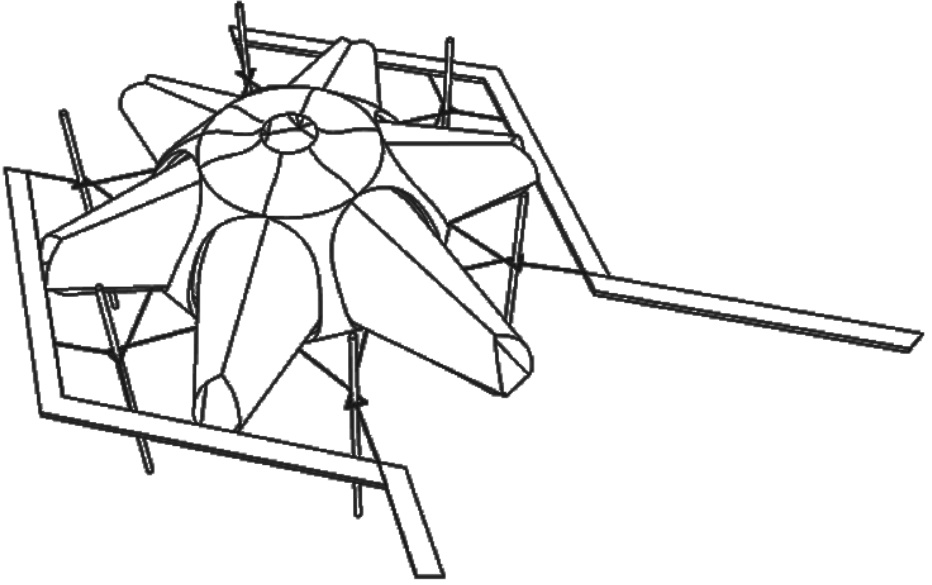
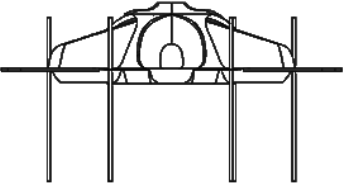
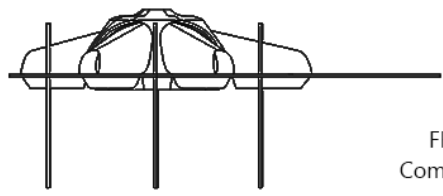
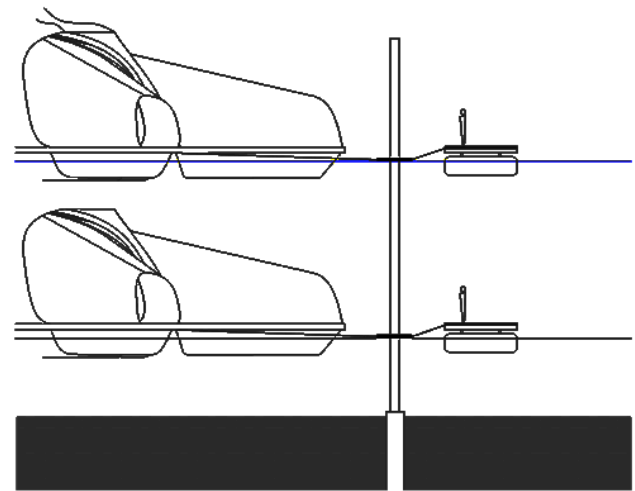
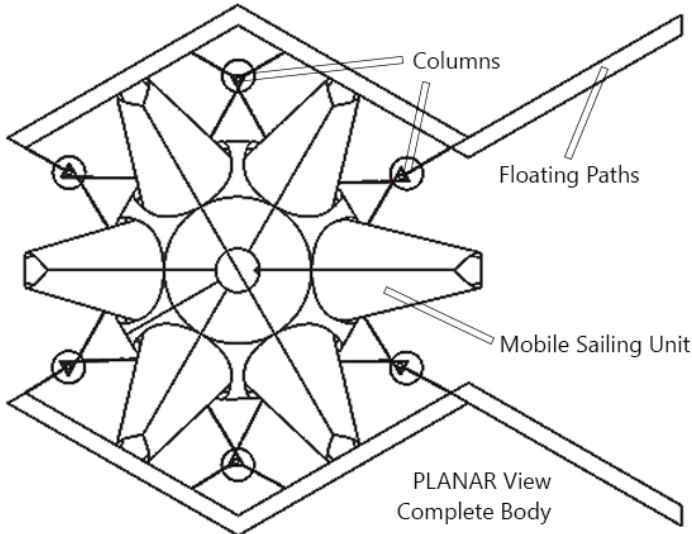
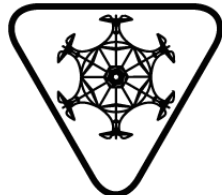



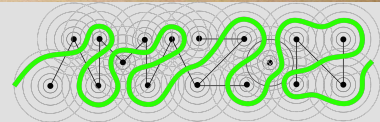



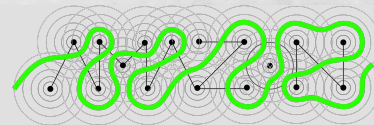
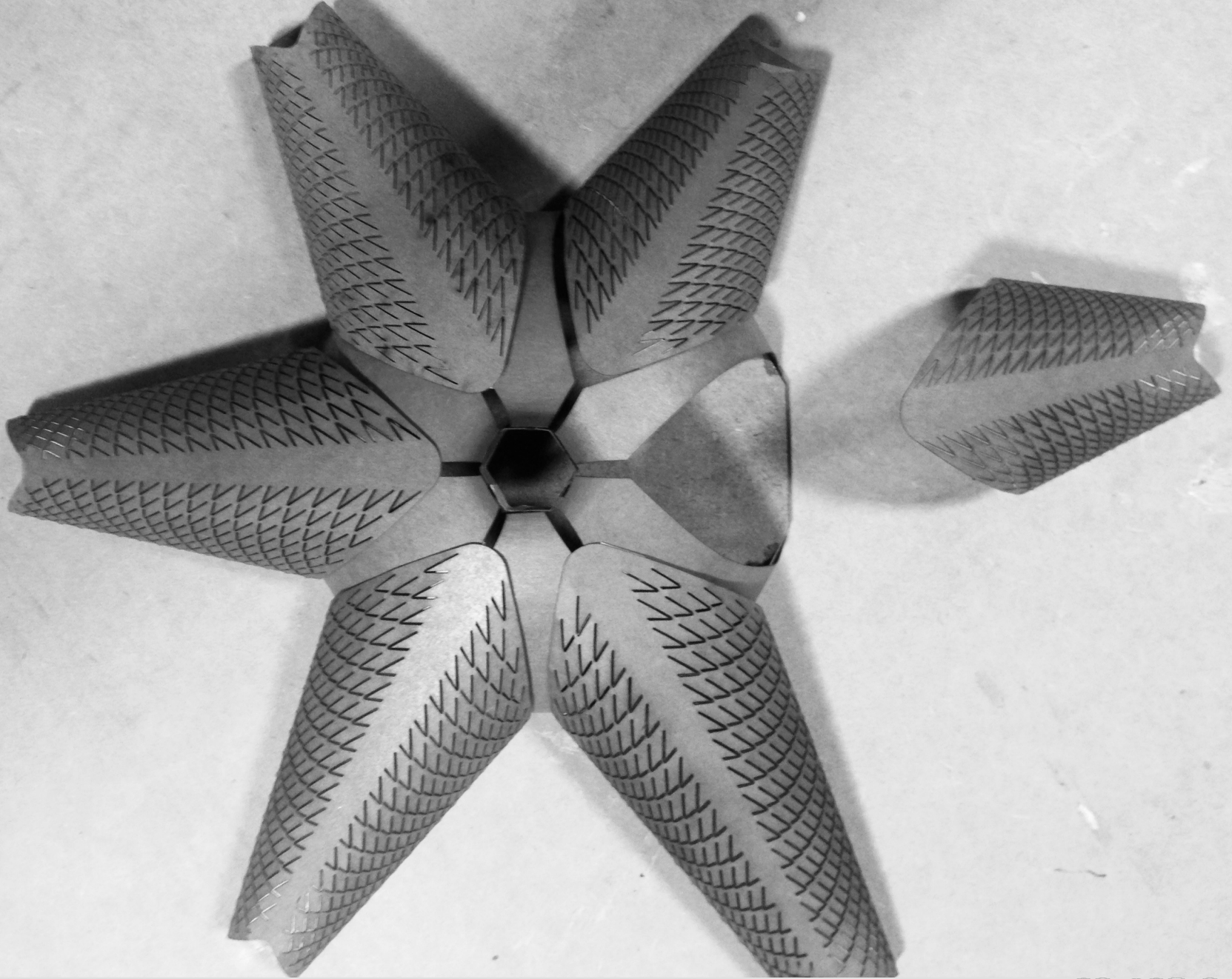



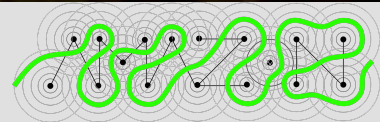
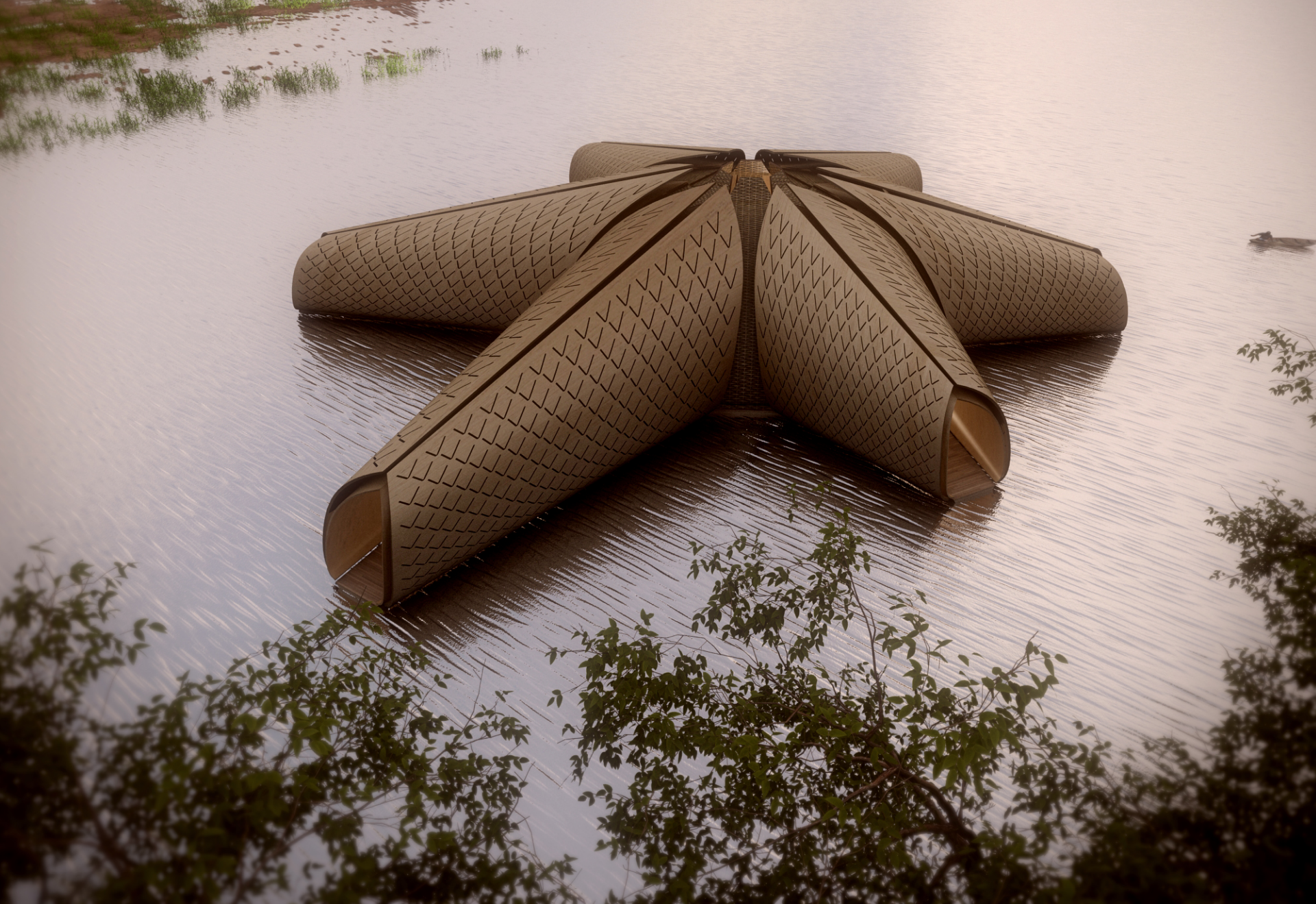



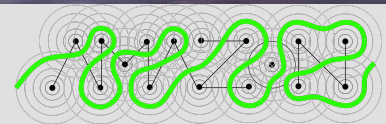



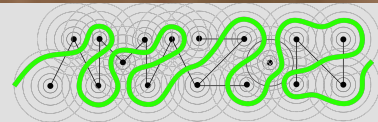



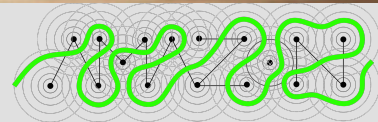
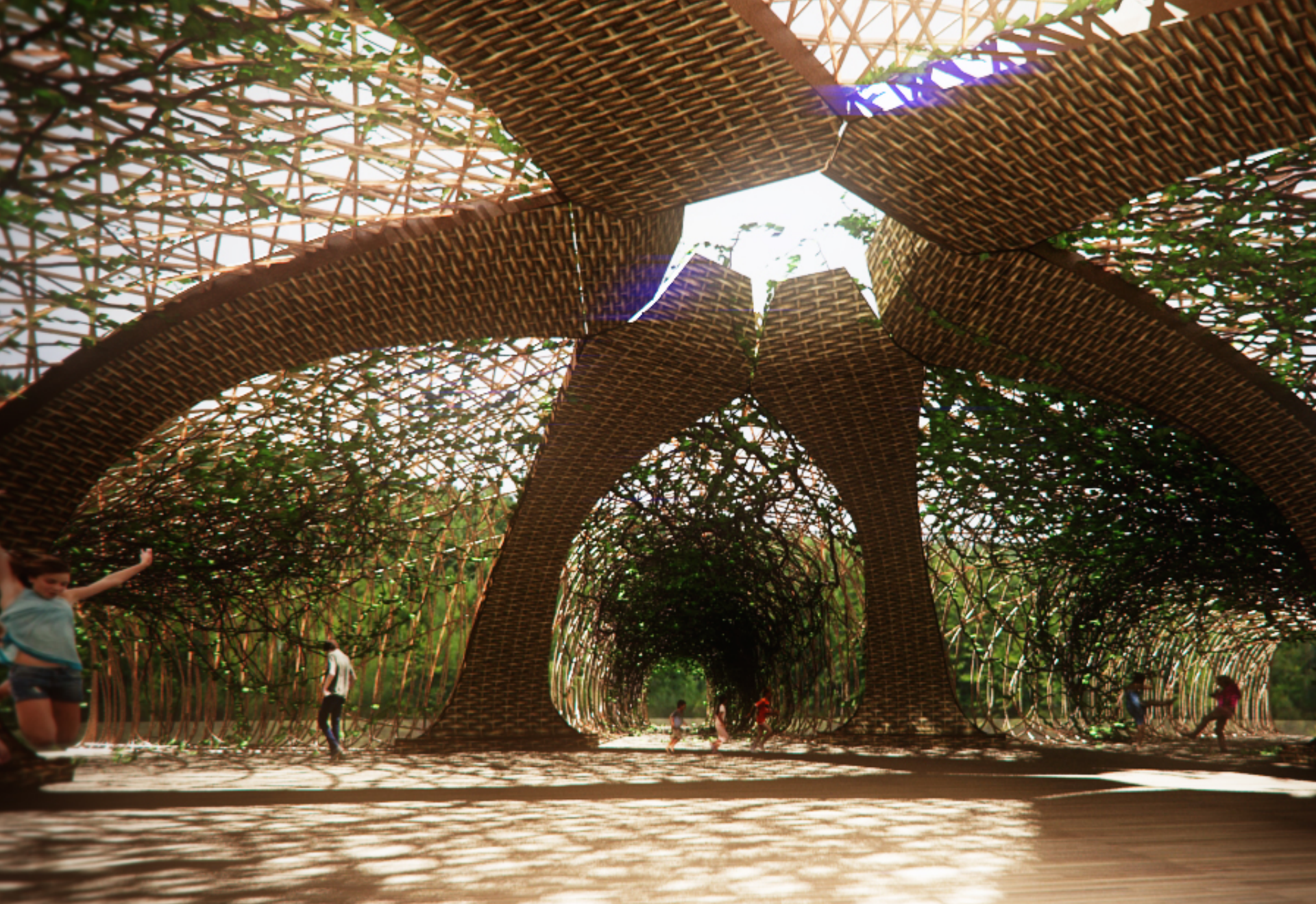



**WE HAVE A TEAM AND WE ARE READY TO BUILD !! THANKS**

